



TECHNICAL MANUAL and INSTALLATION INSTRUCTIONS

V802 Series
35-FOOT WHIP ANTENNAS
REV E
VTM-06-008E

Valcom Manufacturing Group, Inc.

175 Southgate Drive, P.O. Box 603, Guelph, Ontario, Canada N1H6L3 Tel: 519-824-3220 Fax: 519-824-3411

Web Site: www.valcommfg.ca E-mail: enquiries@valcom-guelph.com

V802 Series

TABLE OF CONTENTS

1.0 V802 INFORMATION

1.1 Introduction.....1
1.2 Technical Reference Data.....1
1.3 General Description.....2
1.4 Electrical Description.....2
1.5 Mechanical Description.....2
1.6 Scheduled Maintenance.....3
1.7 Corrective Maintenance.....3

2.0 INSTALLATION

2.1 Unpacking4
2.2 New Site Preparation.....4
2.3 Assembly and Raising.....4
2.4 Electrical Installation.....5

3.0 PARTS LIST

3.1 General.....6

4.0 QUICK REFERENCE DATA

4.1 General.....7
4.2 Manufacturer’s Address.....7

LIST OF FIGURES

(1) FOUNDATION DETAILS FOR VBP-T2A BASE PLATE.....8
(2) V802 WHIP ANTENNA GROUND SCREEN INSTALLATION.....9
(3) TRENCH DETAILS.....10
(4) CONNECTIONS AND CABLE ARRANGEMENTS.....11

V802 Series

1.0 V802 INFORMATION

1.1 Introduction

This section describes the electrical and mechanical properties of the V802 series fibreglass whip antennas. Information necessary to install, operate and maintain the antenna system is covered in the sections to follow.

1.2 Technical Reference Data

Mechanical Properties	
Top Section Length	18 feet (5.5 meter)
Base Section Length	17.8 feet (5.4 meter)
Typical Assembly Length	35.8 feet (11 meter)
Weight	Approximately 73 lbs (33 kg)
Material Finish	Copper wire and strips embedded in the fiberglass and thermo-setting epoxy resin composite; Polyurethane
Mounting Position	Vertical
Base Diameter	12.0 inches (30.48 cm)
Mounting Hole Diameter	0.56 inches (1.43 cm)
Mounting Holes Dimensions	6 places equally spaced on a 10 inch (25.4 cm) diameter bolt
Storage Temperature	-95°C to +70°C (-140°F to +158°F)
Operating Temperature	-50°C to +65°C (-76°F to +140°F)
Wind Loading Test	Up to 150 mph (240 km/hr) relative
Abrasion Resistance	Very Good
Water absorption	After 24 hours immersed: 0.2%
	After 48 hours immersed: 0.6%
	After 168 hours immersed: 2.0% VBP-T2 Steel Base Plate
Optional Accessories	BBMT-50/70 or VMT-7117 Broadband Matching Transformer

V802 Series

Electrical Properties	
Frequency Range	100 kHz to 30 MHz (with capacity of the antenna tuner)
Resonant Frequency	5.93 MHz (nominal)
Power Rating	5kW (average) at 2 MHz to 30 MHz (power derating is necessary for operation lower than 2 MHz)
Dry Withstanding Voltage	25 kV
Electrical Length	35.4 feet (10.8 m)

1.3 General Description

The V802 series whip antennas are intended to be used as part of an overall communication system which consists of a transmitter (or receiver or transceiver), an antenna coupler and the antenna. They are used around the world in many applications with requirements in the 100 kHz to 30 MHz bands for marine and aeronautical radio beacon communication systems.

Numerous model versions of this antenna are available depending on the specific application. The standard V802 is a side-fed, medium duty antenna. The V802FT is a feed-through version, medium duty antenna. The V802M is a rugged military version with drip shields.

1.4 Electrical Description

The Valcom, V-802 model, is a field proven 35-foot (11 m) epoxy fiberglass antenna. It is capable of operating with an average power of up to 5 KW (10 KW peak power) over the frequency range of 1.6 to 30 MHz and at reduced power down to 100 kHz. When the antenna is used in receive mode, it is normally connected to a receiver matching unit, such as a BBMT-50. Or when the antenna is used in transmit mode, it is normally connected to a VMT-7117. Either one is then connected to the associated transceiver(s).

1.5 Mechanical Description

Top-Section. The top-section is a hollow, tapered cylinder made of circumferentially and longitudinally wound fiberglass filaments using a thermosetting epoxy resin matrix. Copper strips are embedded in the composite and are secured at the top end to a hemispherical corona ball and at the bottom end to a female threaded ferrule. The surface is sanded to a smooth finish, then it is primed and painted with a polyurethane surface coating.

V802 Series

Base-Section. The base-section is constructed and finished in the same fashion as for the top-section, except that the diameter expands out to meet the mounting base. Embedded copper conductors are connected to the threaded male ferrule at the top and to a conducting ring near the bottom. The side feed terminal extends from the bottom ring to the surface of the antenna approximately 12.0 inches from the bottom of the base flange. The base can withstand a flash-over voltage of 25 kV.

1.6 Scheduled Maintenance

The antenna is virtually maintenance free. The external finish is an epoxy polyamide two part compound paint. The minimum finish life before showing signs of deterioration should be at least six years under normal climate condition. When used in salt-water environments, it is recommended to wash the antenna base with fresh water to remove any build-up of dried salt residue. This should be performed on a monthly basis or after prolonged exposure to sea-spray. Use a small wire brush to clear any debris from the drain groove found in the bottom of the antenna base. All threaded hardware, including the base mounting bolts, the set-screws at the joint and the input power connection should be inspected for signs of damage and to ensure proper tightness (suggested torque settings can be found on pages 4 and 5). In most cases a quick visual inspection is all that is required. This must be performed on a monthly basis or whenever practical.

1.7 Corrective Maintenance

Generally, no corrective maintenance is possible or required. If one section is severely damaged, it must be replaced by a new section. Workshops having experience in handling epoxy fibreglass composite structures may attempt the repair of minor surface damage if practicable.

NOTE

DO NOT USE LEAD BASE PAINT TO TOUCH-UP OR REPAINT THE ANTENNA. USE ONLY EPOXY BASE PAINT.

V802 Series

2.0 INSTALLATION

2.1 Unpacking

Open the shipping crates and remove the antenna sections and any possible accessories purchased with it. Remove all packing material including the male ferrule protector on the antenna section. The V802 antenna, as shipped, consists of the items listed in Table 3.1. Check that all of the items are present and in good condition.

2.2 New Site Preparation

The following are the basic steps to erect a complete V802 antenna system on land. Other configurations should be handled accordingly.

- (1) Check to see that the site is free of cables, debris and other obstructions.
- (2) Excavate and pour concrete pad in the site chosen (see Foundation Details for VBP-

T2A Base Plate).

- (3) Excavate trench in site chosen (see Trench Details).
- (4) Install Ground Screen in site chosen (see V802 Whip Antenna Ground Screen Installation).
- (5) Lay cables and backfill all trenches
- (6) Erect antenna

2.3 Assembly and Installation of Antenna on the site

The following steps should be followed to assemble the V802 whip antenna (see Installation Layouts).

- (1) Obtain four saw horses or other supports that will hold the complete antenna

horizontally at a convenient working height and place them in the assembly area. The assembly area must be a cleared working space approximately 40 feet long and 20 feet wide.

- (2) Support the base section (item 1, Table 3.1) on two of the saw horses.
- (3) Assemble the VBP-T2A base plate (if purchased) to the base antenna section, secure base section to the plate with hardware supplied, fed through from underside. A final torque between 90-100 ft-lbs is acceptable for the bolts.
- (4) Support the top section (item 2, Table 3.1) on the other two saw horses so that the two sections lie in the same straight line.

V802 Series

- (5) Make sure the threads of the male ferrule on the base section are clear of foreign material and not damaged.
- (6) Assemble the second antenna section onto the base section and tighten to align the arrows (if applied) at the joint using the strap wrench supplied (item 3, Table 3.1). Install the set screws at the joint and seal over with the sealant provided. A final torque between 65-85 in-lbs is acceptable for the set screws.
- (7) The antenna is now ready to be raised to its final position. A minimum of three people are required to raise the antenna upright onto the foundation. Other options are to use a crane or a bucket truck.
- (8) Once the antenna is in the vertical position, secure the base plate to the foundation with the hardware provided. Otherwise, secure the antenna to the foundation with appropriate ½" hardware. A final torque between 90-100 ft-lbs is acceptable for the bolts.
- (9) Make an electrical connection from the Ground Screen to the Base Plate, then proceed to Section 2.4 Electrical Installation.

2.4 Electrical Installation

A) If a third party coupler is being used, connect a suitable feed wire from the antenna to the coupler.

B) If Valcom tuner or transformer is used, then two leads made of heavy gauge solid copper wire are provided with the matching unit: the output lead to the antenna and the ground lead. The output lead may be gently bent to conform to the distance between the output connector on the matching unit and the antenna feed point. The ground lead is to be connected between any one of the four mounting bolts on the matching unit enclosure (available separately) and the antenna ground screen. Determine the length of lead required to reach the ground screen (the shorter the better). Next, cut the lead to the appropriate length and scrape the protective varnish off the end. Now using a torch and solder, braze the end of the ground lead to the antenna ground screen. Finally connect the terminal lug on the other end of the ground lead to the mounting stud on the matching unit enclosure.

Connect a suitable coaxial line from the transmit/receive equipment to the N-type connector of the matching unit.

The coupler (available separately) has been pre-tuned at the factory with the accompanying antenna to the frequency band requested. No adjustments should be necessary.

V802 Series

3.0 PARTS LIST

3.1 General

A list of parts shipped with Valcom V802 whip antenna appears in Table 3.1.

Table 3.1 - List of Parts for the V802 Whip Antenna

Item No.	Part Number	Description	Qty	Notes
1		Base Section(V802)	1	
2		Top Section	1	
3		Strap Wrench	1 ea	
4		Silicone Sealant	1	
5		Setscrew Kit	1 set	
6		Technical Manual and Installation Instructions	1 ea	

Table 3.2 -Listof parts required for full installation (Shipped separately)

Item No.	Part Number	Description	Qty	Notes
1	VBP-T2A	Base Plate for V-802 Antenna	1	Optional
2	VD-00-00051-1	Ground screen kit for V-802 Antenna	1	Optional
3	VMT-7117	Matching unit	1	Optional
4		Hardware kit	1set*	Optional

***Hardware Package Parts List:**

1. Cap screw, Hex Hd, ½-13UNC-2A x 3-½ lg, Corrosion Resistant Steel, Qty: 6
2. Nut, Hex, ½-13UNC-2B, Corrosion Resistant Steel, Qty: 10
3. Flat washer, ½ Nom, Corrosion Resistant Steel, Qty: 16
4. Washer, Lock-spring, Helical, ½ Nom, Corrosion Resistant Steel, Qty: 16
5. Cap screw, Hex Hd, ¼-20UNC-2B x 5/8 lg, Stainless Steel, Qty: 4
6. Flat washer, ¼ Nom, Stainless Steel, Qty: 4
7. Washer, Lock-spring, Helical, ¼ Nom, Stainless Steel, Qty: 4
8. Wire to connect matching unit to antenna
9. Wire to connect matching unit to ground

V802 Series

4.0 QUICK REFERENCE DATA

4.1 General

Quick reference engineering data and illustrations for use during planning and installation activities for the V802 whip antenna are presented on the following pages.

- Foundation Details For VBP-T2A Base Plate.
- V802 Whip Antenna Ground Screen Installation.
- Trench Details.
- Installation Layout Instructions Valcom V802 Whip Antenna, VBP-T2A, VMT-7117.
- Connections and Cable Arrangements.
- Quick Reference Data - VBP-T2A Base Plate.
- Valcom's V802 Whip Antenna

4.2 Manufacturer's Address

Postal address:
Valcom Manufacturing Group, Inc P.O. Box 603 Guelph, Ontario Canada N1H 6L3

Shipping address:
Valcom Manufacturing Group, Inc 175 Southgate Drive Hanlon Industrial Park Guelph, Ontario Canada N1G 3M5

FOUNDATION DETAILS FOR VBP-T2A BASE PLATE

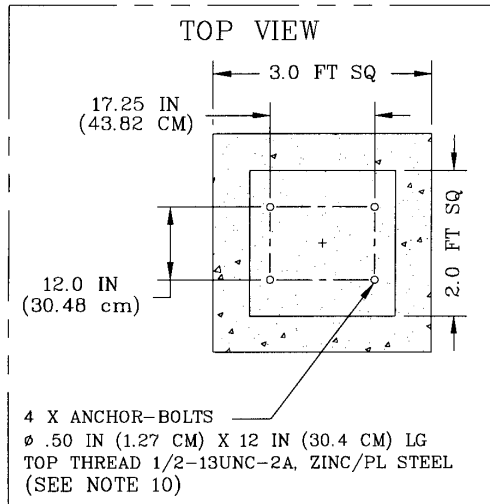

NOTES:

1. FOUNDATION BASE TO BE ON UNDISTURBED SOIL.
2. FOUNDATION EXCAVATION MUST BE FREE OF WATER BEFORE PLACEMENT OF CONCRETE.
3. DURING PLACEMENT OF CONCRETE, MAXIMUM FREE FALL DISTANCE SHALL NOT EXCEED THREE FEET (0.914cm)
4. ALL CONCRETE PLACED DURING FREEZING TEMPERATURES SHALL BE PRE-HEATED AND PROPERLY PROTECTED DURING CURING. ALL HANDLING AND PLACEMENT TO BE IN ACCORDANCE WITH GOOD CONSTRUCTION PRACTICE.
5. MINIMUM 28 DAY COMPRESSIVE STRENGTH-3,000 PSI
6. AIR ENTRAINED CONCRETE 6% ± 1
7. SLUMP RANGE OF CONCRETE DURING PLACEMENT, 1.5 TO 4.5 INCHES (3.7 TO 11.2cm).
8. BACKFILL MATERIAL SHALL BE FREE FROM DEBRIS OF ANY KIND INCLUDING ICE, SNOW OR FROZEN MATERIAL.
9. WHERE THE SOIL CONDITIONS WARRANT, THEN SULPHUR RESISTANCE CONCRETE SHOULD BE USED.
10. RECOMMEND THE USE OF PLYWOOD AS A TEMPLATE FOR 4 ANCHOR-BOLTS BEFORE PLACEMENT OF CONCRETE.

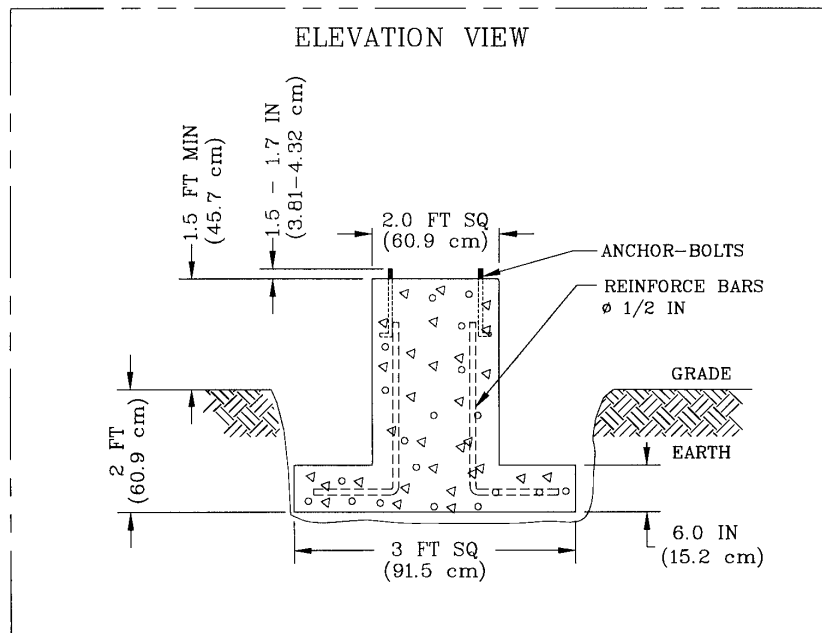

V802 Series

V802 WHIP ANTENNA GROUND SCREEN INSTALLATION

Copper mesh, 1/2" X
1/2" X .045" thick, 3
pieces 12' X 4'

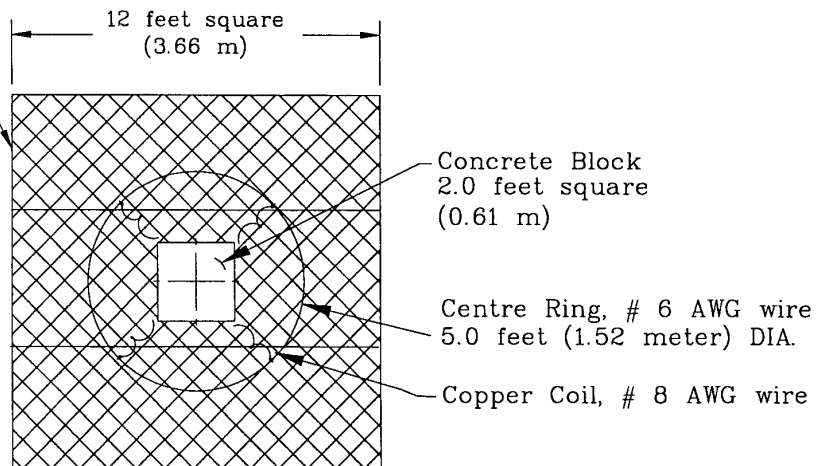

NOTES:

1. THE THREE PIECES OF COPPER MESH MUST BE TIED TOGETHER BY USING SOME EXTRA #20 AWG COPPER WIRE AND SHOULD BE SOLDERED.
2. THE CENTRE RING (# 6 COPPER WIRE) IS PLACED ON TOP OF THE COPPER MESH AND SHOULD BE SOLDERED BY USING EXTRA #20 AWG COPPER WIRE.
3. THE AREA OF THE MESH SCREEN MUST BE DUG OUT 12 INCHES (30.5 CM) TO HAVE GROUND SCREEN PLACED UNDER GROUND.
4. TAKE THE COILED # 8 COPPER WIRE AND RUN IT FLAT ALONG THE GROUND TO THE CONCRETE FOUNDATION. RUN IT UP THE SIDE OF THE FOUNDATION AND CONNECT TO THE MOUNTING PLATE. CUT OFF EXCESS WIRE.

V802 Series

TRENCH DETAILS

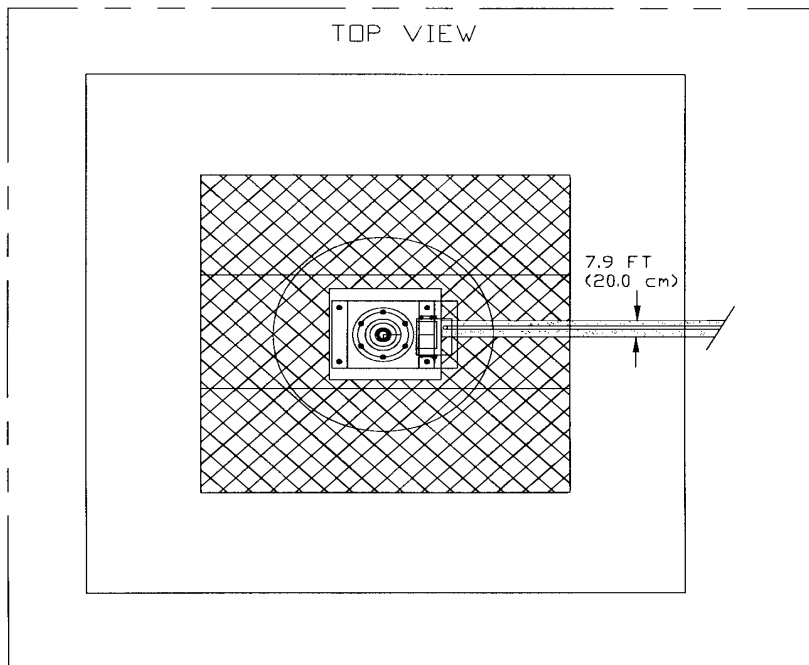
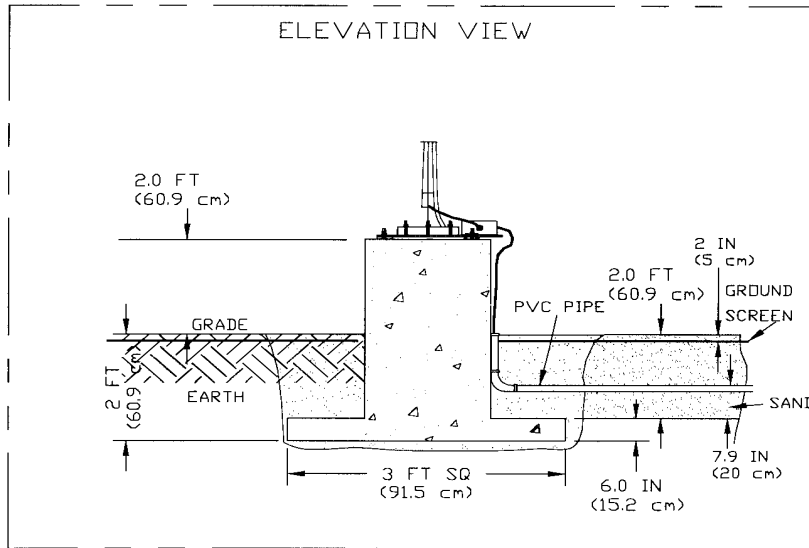

INSTALLATION DETAILS

HARDWARE REQUIREMENT

- CAP SCREW, HEX HD, 1/2-13 UNC X 3.5 LG, CRESS., QTY 6
- FLAT WASHER, 1/2 NOM., CRESS., QTY 16
- WASHER, LOCK-SPRING, 1/2 NOM., CRESS., QTY 10
- NUT, HEX HEAD, 1/2-13UNC-2B, CRESS., QTY 10
- CAP SCREW, HEX HEAD, CRESS., 1/4-20UNC-2A X .50 LG, QTY 4
- FLAT WASHER, 1/4 NOM, CRESS., QTY 4
- WASHER, LOCK-SPRING, 1/4 NOM, CRESS., QTY 4

INSTALLATION

- EXCAVATION AND POURING OF CONCRETE PAD (SEE FOUNDATION DETAILS FOR VBP-T2A BASE PLATE)
- INSTALLATION GROUND SCREEN (SEE V132, V252, V353 AND V802 WHIP ANTENNA GROUND SCREEN INSTALLATION)
- INSTALL VBP-T2A BASE PLATE AND ANTENNA ON THE FOUNDATION.
- MAKE ELECTRICAL CONNECTION FROM COPPER COILS OF THE GROUND SCREEN TO BASE PLATE.
- INSTALL VMT-7117 ON BASE PLATE (OPTIONAL), MAKE SURE A GOOD ELECTRICAL GROUND CONNECTION TO CHASSIS OF VMT-7117.
- CONNECT THE SIDE FEED LINE OF ANTENNA TO OUTPUT OF VMT-7117.

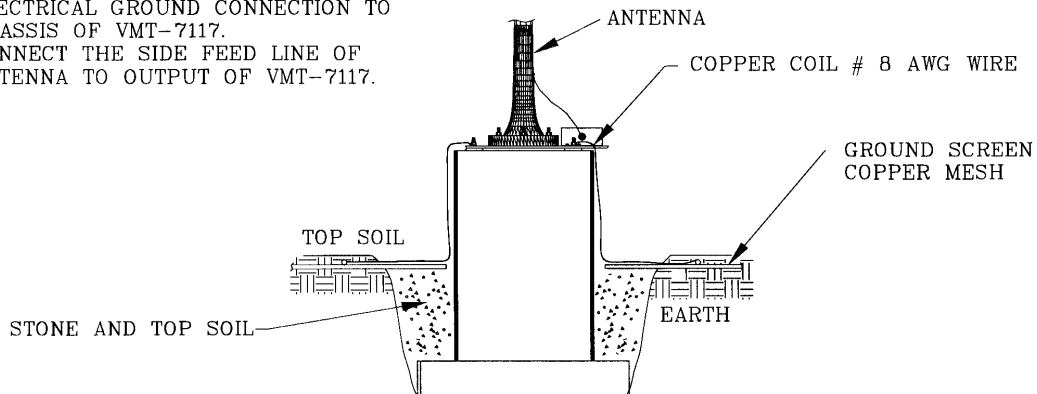
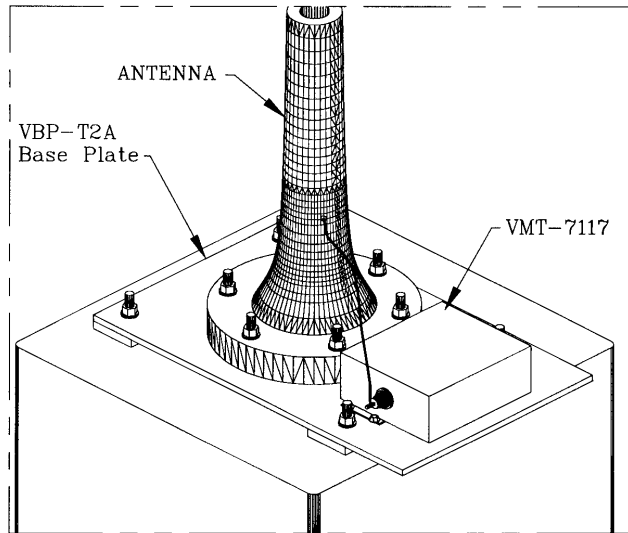

V802 Series

CONNECTIONS AND CABLE ARRANGEMENTS

