



TECHNICAL MANUAL and INSTALLATION INSTRUCTIONS

V33085AM-CL ANTENNA

VTM-05-004A

Valcom Manufacturing Group, Inc.

175 Southgate Drive, P.O. Box 603, Guelph, Ontario, Canada N1H6L3 Tel: 519-824-3220 Fax: 519-824-3411

Web Site: www.valcommfg.ca E-mail: enquiries@valcom-guelph.com

TABLE OF CONTENTS

<u>Section</u>	<u>Page</u>
1.0 GENERAL INFORMATION AND SAFETY PRECAUTIONS	1
1.1 General Safety Precautions.....	1
1.2 Specific Warnings.....	1
1.3 Introduction.....	2
1.4 Technical Reference Data.....	2
2.0 FUNCTIONAL DESCRIPTION	4
2.1 General.....	4
2.2 Electrical Description	4
2.3 Mechanical Description.....	4
3.0 MAINTENANCE	5
3.1 Scheduled Maintenance.....	5
3.2 Corrective Maintenance.....	5
4.0 INSTALLATION	6
4.1 Unpacking.....	6
4.2 New Site Preparation.....	6
4.3 Assembly and Installation of Antenna on the Site.....	6
4.4 Electrical Installation.....	7
5.0 PARTS LIST	9
5.1 General.....	9
6.0 QUICK REFERENCE DATA	10
6.1 General.....	10
6.2 Manufacturer's Address.....	10

V33085AM-CL

LIST OF TABLES AND FIGURES

<u>Table or Figure</u>	<u>Page</u>
Table 1-1 - Electrical Properties of the V33085AM-CL.....	2
Table 1-2 - Mechanical Properties of the V33085AM-CL.....	3
Table 5-1 - List of Parts for the V33085AM-CL.....	9
Figure 4-1 - Gin Pole Arrangement.....	8

APPENDICES

- C Quick Reference Data - V33085AM-CL Antenna
- C Foundation Details For VHB-17AM Hinge Plate or VTGS -20BH AM Steel Tower
- C Quick Reference Data - VHB-17AM Hinge Plate
- C Quick Reference Data - VGS-120XXXAM Ground Screen
- C AM Antenna Ground Screen Installation

SECTION 1.0

GENERAL INFORMATION AND SAFETY PRECAUTIONS

1.1 GENERAL SAFETY PRECAUTIONS

The following general safety precautions are not related to any specific procedures and therefore do not appear elsewhere in this publication. These are recommended precautions that personnel must understand and apply during many phases of operation and maintenance.

WARNING

Keep away from live circuits. Operating personnel must at all times observe all safety regulations, to prevent serious injury or death due to electrical shock.

Do not service or adjust alone. Under no circumstances should any person service or adjust the equipment except in the presence of someone who is capable of rendering aid.

Personnel working with or near high voltages should be familiar with modern methods of resuscitation.

1.2 SPECIFIC WARNINGS

The following specific precautions are related to inspecting and removing the antenna.

WARNING

Ensure that the transmitting equipment is de-energized prior to inspection of the antenna. Make sure the test equipment is properly grounded, to prevent electric shock.

CAUTION

Make sure the antenna is properly supported before removing its mounting hardware.

CAUTION

Do not coat the insulator with any substance; do not paint with lead base paints.

V33085AM-CL

1.3 INTRODUCTION

This manual describes the electrical and mechanical properties of the V33085AM-CL antenna. It provides the information necessary to install, operate and maintain the antenna.

1.4 TECHNICAL REFERENCE DATA

Table 1-1 Electrical Properties of the V33085AM-CL

PARAMETER	SPECIFICATION
FREQUENCY RANGE	100 kHz to 30 MHz (with capacity of the antenna tuner)
RESONANT FREQUENCY	540 kHz to 1700 kHz (as specified by customer)
BAND WIDTH	Dependant on Resonant Frequency (Typically > 20kHz)
ELECTRICAL LENGTH	Dependant on Loading Coil
POWER RATING	2 kW 540 to 600 kHz 5 kW 600 to 1000 kHz 10 kW 1000 to 1700 kHz
DRY WITHSTANDING VOLTAGE	30 kV

V33085AM-CL

Table 1-2 Mechanical Properties of the V33085AM-CL

PARAMETER	SPECIFICATION
Assembled Length	85 feet (25.9 m)
Weight	895 lbs (406 kg)
Material	Copper wire and strips embedded in the fiberglass and thermo-setting epoxy resin composite Epoxy polyamide paint
Finish	Vertical
Mounting Position	17.5 inches (44.45 cm)
Base Diameter	0.718 inches (1.82 cm)
Mounting Hole Diameter	12 places equal spaced on a 14.625 inch (37.15 cm) diameter
Mounting Holes Dimensions	bolt circle -95EC to +70EC (-140EF to +158EF)
Storage Temperature	-50EC to +65EC (-60EF to +150EF)
Operating Temperature	Up to 150 mph (241 km/hr) relative
Wind Loading Test	Very Good
Abrasion Resistance	After 24 hours immersed: 0.2% After 48 hours immersed: 0.6% After 168 hours immersed: 2.0%
Water absorption	VHB-17AM Steel Hinge Plate VGP-17AM Gin Pole and Adapter VGS-120XXXAM Ground Screen
Optional Accessories	

V33085AM-CL

SECTION 2.0

FUNCTIONAL DESCRIPTION

2.1 GENERAL

The V33085AM-CL is intended to be used as part of an overall communication system which consists of a transmitter (or receiver or transceiver), an antenna coupler and the antenna. It is used around the world in many applications with requirements in the 100 kHz to 1700 kHz bands for AM broadcast communication systems as well as marine and aeronautical radio beacon systems.

2.2 ELECTRICAL DESCRIPTION

The Valcom Model V33085AM-CL antenna is a field proven, 85-foot antenna. The field strength of the antenna is radiated by the copper strips embedded inside the fiberglass and thermo-setting epoxy resin composite. The second or third sections are inductively loaded to a resonant frequency slightly higher than the operating frequency specified by the customer in order to allow room for fine-tuning.

2.3 MECHANICAL DESCRIPTION

Non-Coil-Loaded Sections. These are hollow tapered cylinders made of circumferentially and longitudinally wound fiberglass filaments using a thermosetting epoxy resin matrix. Embedded in the composite are multiple beryllium copper strips laid in a single-turn spiral and secured at the top end to a respective male ferrule and at the bottom to a threaded female ferrule into which the next section is secured. The surface is smoothed, primed and painted with a polyamide epoxy surface coating.

Coil-Loaded Section. The coil-loaded section is constructed in a similar manner as the non-coil-loaded sections, except an enameled copper wire is used to wind the coil instead of copper straps. The ends of the coil are brazed to their respective ferrules.

Base Section. The construction and finish are the same as for the other sections except that the diameter expands out to meet the mounting base. The ferrule is threaded to fit into the bottom of the Second section. Multiple parallel conductors are connected to the ferrule at the top and to a conducting ring near the bottom. The feed terminal extends from the bottom ring to the surface of the antenna approximately 18.0 inches from the bottom of the base flange. The base can withstand a flash-over voltage of 30 kV.

NOTE: The sections of the antenna cannot be interchanged with other antennas due to the unique locations of the locking screw holes.

V33085AM-CL

SECTION 3.0

MAINTENANCE

3.1 SCHEDULED MAINTENANCE

The antenna is virtually maintenance free. The external finish is an epoxy polyamide two part compound paint. The minimum finish life before showing signs of deterioration should be at least six years under normal climate condition. Periodically (roughly every six months) inspect the drain groove in the bottom of the base and ensure it is clean of all debris. When used in salt-water environments, it is recommended to wash the antenna base with fresh water to remove any build-up of dried salt residue. This should be performed on a monthly basis or after prolonged exposure to sea-spray. Use a small wire brush to clear any debris from the drain groove found in the bottom of the antenna base.

3.2 CORRECTIVE MAINTENANCE

Generally, no corrective maintenance is possible or required. If one section is severely damaged, it must be replaced by a new section. Workshops having experience in handling epoxy fibreglass composite structures may attempt the repair of minor surface damage if practicable.

NOTE

**DO NOT USE LEAD BASE PAINT TO TOUCH-UP OR REPAINT
THE ANTENNA. USE ONLY EPOXY BASE PAINT.**

V33085AM-CL

SECTION 4.0

INSTALLATION

4.1 UNPACKING

Open the shipping crates and remove the antenna sections. Remove all packing material including the male ferrule protectors on the antenna sections. The V33085AM-CL antenna, as shipped, consists of the items listed in Table 5-1. Check that all of the items are present and in good condition.

4.2 NEW SITE PREPARATION

- (1) Excavate and pour the concrete pad (see Foundation Details for VHB-17AM Hinge Plate/VTGS-20AM Steel Tower in appendix section).

Install Ground Screen in accordance with Valcom's Specification VED-99-0001 (in appendix section).

- (2) **ASSEMBLY AND INSTALLATION OF ANTENNA ON THE SITE**

4.3

The following steps should be followed while assembling the V33085AM-CL antenna (see Figure 4-1).

- (1) Remove retainer pin on the hinge plate and open top plate to 90 degrees, mount the bottom plate of the hinge plate on the anchor bolts.
- (2) Secure with hardware (flat washer, lock washer, and nut) on each bolt. Obtain six saw horses or other supports that will hold the complete antenna horizontally at a convenient working height and place them in the assembly area.
- (3) The assembly area must be a cleared working space approximately 120 feet long and 20 feet wide. Support the base section (item 1 of Table 5-1) on two of the saw horses.
- (4) Align mounting holes in the plate with holes of the antenna flange and gin pole adapter, secure base section to the plate with hardware, fed through from underside. Make sure the feed point terminal of the antenna will end up in a convenient location for connecting the coupler.
- (5) Tie a rope (3/4" diameter polypropylene) to the eye of the gin pole, tie two other ropes the same type to the eye of the gin pole. Slide gin pole into the pipe attachment and secure with hardware provided.

V33085AM-CL

- (6) Support the second section (item 2 of Table 5-1) on the other two saw horses so that the two sections lie in the same straight line.
- (7) Make sure the threads of the male ferrule on the base section and the threads of the female ferrule on the next section are clear of foreign material and free of burrs.
- (8) Assemble the second antenna section onto the base section and tighten to align the arrows at the joint using the strap wrench supplied (item 7 of Table 5-1).
- (9) Secure two sections by using the hex lock screws supplied. Seal the hex screws with silicone sealant (item 8 of Table 5-1).

Assemble the third section (item 3 of Table 5-1) to the second section by repeating steps 6 to 8.

- (10) Assemble the fourth and fifth sections (items 4 and 5 of Table 5-1) by repeating steps 6 to 8.
- (11) After all sections are assembled, assemble the Valcosphere and Top-Hat assembly (if applicable) to the top of the fifth section with adapter provided. The antenna now is ready to raise to its final position.
- (12) Tie the three ropes (from gin pole eye) to the first three transition points on antenna (see Figure 4-1). A timber hitch knot is recommended.
- (13) Erect antenna by applying a gradual and constant pull on the rope referred to as the “Pulling Force” (a winch or vehicle is recommended).
- (14) Once the antenna is in the vertical position, insert retainer pin back into hinge plate, secure with tension pin. Use bolts (supplied) to secure upper and lower plates of the hinge plate together.
- (15) Remove the gin pole. Electrical connections can now be made.

4.4 ELECTRICAL INSTALLATION

Very carefully secure the lead wire from the tuner the antenna by means of the acorn screw and lock-washer provided.

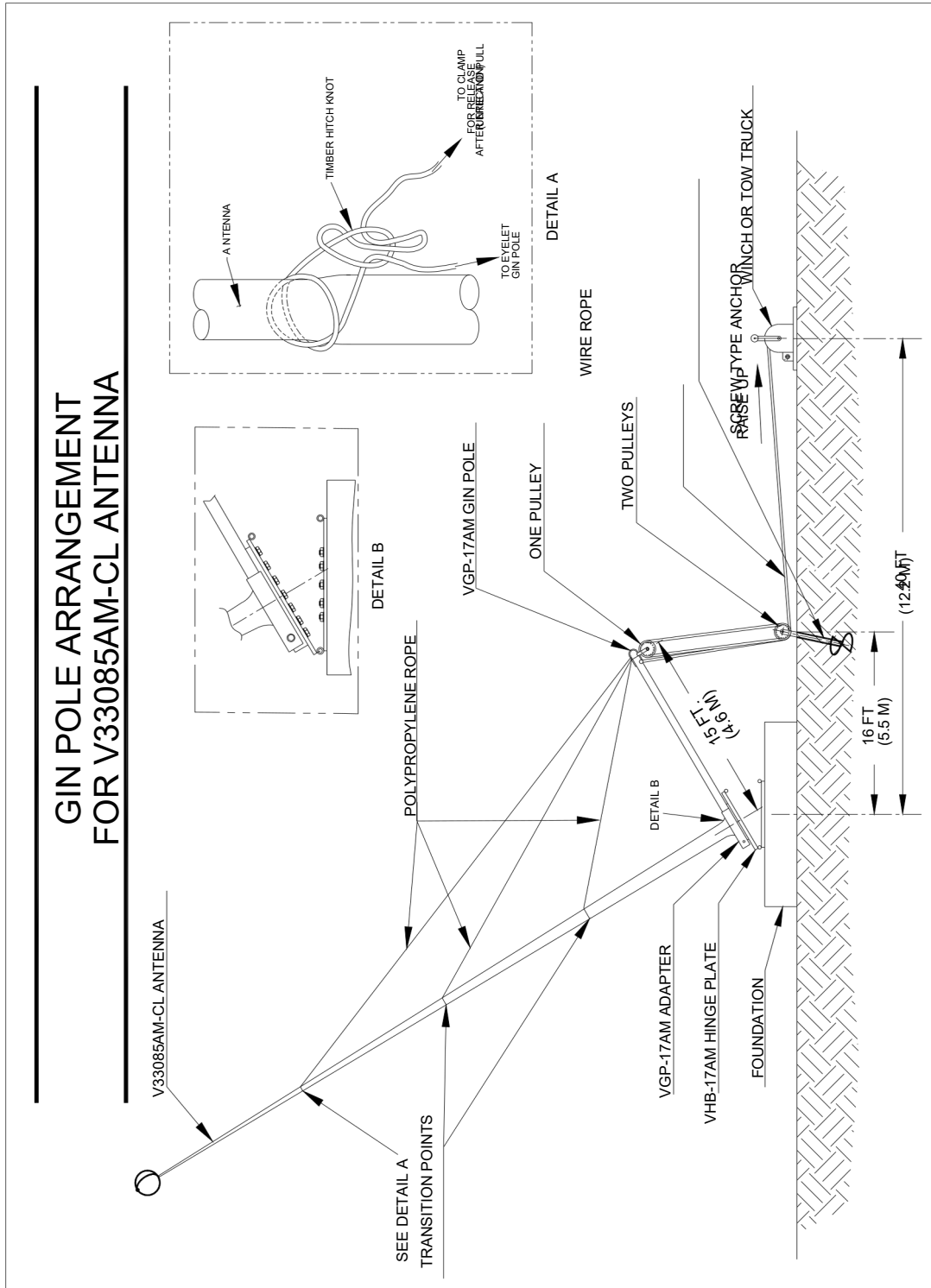

Figure 4-1 - Gin Pole Arrangement

V33085AM-CL

SECTION 5.0

PARTS LIST

5.1 GENERAL

A list of parts shipped with the V33085AM-CL antenna appears in Table 5-1.

Table 5-1 - List of Parts for the V33085AM-CL Antenna

Item No.	Part Number	Description	Qty	Notes
1	VD-99-00085	Base Section Section 2	1	
2	VD-99-00086 VD-99-00076	(Strap only) Section 2 (Coil-Loaded)	1	
3	VD-99-00087 VD-99-00077 VD-99-00088	Section 3 (Strap Only) Section 3 (Coil-Laded) Section 4 Section 5	1	
4	VD-05-00089	Valcosphere Strap	1	
5	VD-77-00132	Wrench Silicone Sealant	1	
6			1	
7			1	
8			1	
9		Hardware Package (Washer, Lock-Spring, Helical, 3/8 inch nominal, Phosphor Bronze, secure hex screws)	1 set	

V33085AM-CL

SECTION 6.0

QUICK REFERENCE DATA

6.1 GENERAL

Quick reference engineering data for use during planning and installation activities for the V33085AM-CL antenna is presented on the following pages.

- * Quick Reference Data - V33085AM-CL Antenna
- * Foundation Details For VHB-17AM Hinge Plate or VTGS-20BH AM Steel Tower
- * Quick Reference Data - VHB-17AM Hinge Plate
- * Quick Reference Date - VGS-120XXXAM Ground Screen
- * AM Antenna Ground Screen Installation VED-99-0001

6-2 MANUFACTURER'S ADDRESS

Postal address:
Valcom Manufacturing Group, Inc. P.O. Box 603 Guelph, Ontario Canada N1H 6L3

Shipping address:
Valcom Manufacturing Group, Inc. 175 Southgate Drive Guelph, Ontario Canada N1G 3M5

V33085AM-CL

V33085AM-CL2 QUICK REFERENCE DATA

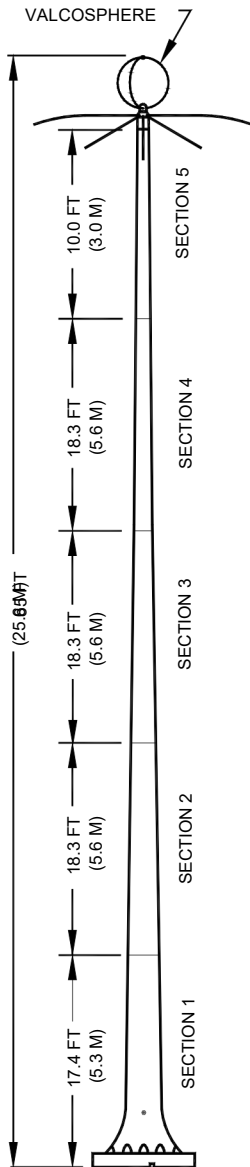

ELECTRICAL CHARACTERISTICS

RESONANT FREQUENCY (f ₀)	540 - 1700 KHZ (SPECIFIED BY CUST)
POWER RATING (*WITH TOP RADIALS)	2 KW FOR FREQ OF 540 - 600 KHZ 5 KW FOR FREQ OF 600 - 1000 KHZ 10 KW FOR FREQ OF 1000 - 1700 KHZ
DRY WITHSTANDING VOLTAGE	
ELECTRICAL LENGTH	30 KV
POSITION OF LOADING COIL	DEPENDANT ON f ₀
OPERATING FREQUENCY	2ND SECTION
INPUT IMPEDANCE AT f ₀	SPECIFIED BY CUSTOMER
Q AT OPERATING FREQUENCY	DEPENDANT ON f ₀
	DEPENDANT ON f ₀

MECHANICAL CHARACTERISTICS

MECHANICAL LENGTH	85 FT (25.9 M)
VALCOSPHERE	32 IN (81.3 CM) DIA
ANTENNA MATERIAL	FILAMENT WOUND EPOXY/FIBREGLASS
TOP TERMINATION	VALCOSPHERE
JOINTS	BRONZE FERRULE C/W LOCKING PIN
WIND LOADING TEST	150 MPH (241 KPH)
TEMPERATURE	-60°F TO 150°F (-50°C TO 65°C)
FINISH	EPOXY POLYAMIDE PAINT
WEIGHT	895 LBS (406 KG) MAX

NOTES:

1. ADVANTAGE OF CENTRE LOADING COIL IS REDUCED RESONANCE OVER A STRAIGHT WHIP AND THEREFORE REDUCED BASE FEED VOLTAGE AND GREATER POWER HANDLING CAPABILITY.
2. DO NOT USE LEAD BASE PAINT TO TOUCH-UP OR REPAINT ANTENNA.

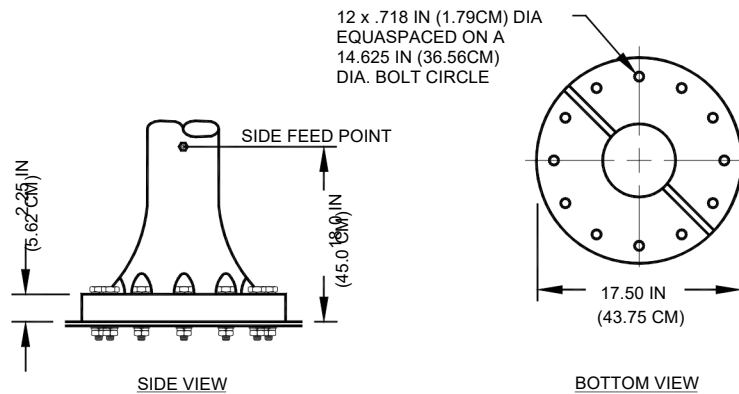

P.O. BOX 603 GUELPH, ONTARIO, CANADA, N1H 6L3
 TEL 519-824-3220 FAX 519-824-3411
 INTERNET: www.valcom-guelph.com EMAIL: enquiries@valcom-guelph.com

FOUNDATION DETAILS FOR VHB-17AM HINGE PLATE OR VTGS-20BH AM STEEL TOWER

NOTES:

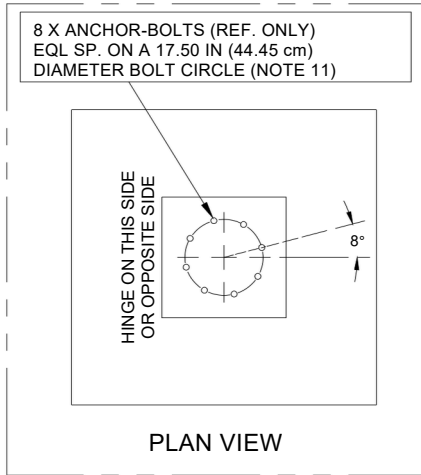

1. FOUNDATION BASE TO BE ON UNDISTURBED SOIL.
2. FOUNDATION EXCAVATION MUST BE FREE OF WATER BEFORE PLACEMENT OF CONCRETE.
3. DURING PLACEMENT OF CONCRETE, MAXIMUM FREE FALL DISTANCE SHALL NOT EXCEED FOUR FEET (120cm)
4. ALL CONCRETE PLACED DURING FREEZING TEMPERATURES SHALL BE PRE-HEATED AND PROPERLY PROTECTED DURING CURING. ALL HANDLING AND PLACEMENT TO BE IN ACCORDANCE WITH GOOD CONSTRUCTION PRACTICE.
5. MINIMUM 28 DAY COMPRESSIVE STRENGTH-3,000 PSI
6. AIR ENTRAINED CONCRETE 6% ± 1
7. SLUMP RANGE OF CONCRETE DURING PLACEMENT, 1.5 TO 4.5 INCHES (3.7 TO 11.2cm).
8. BACKFILL MATERIAL SHALL BE FREE FROM DEBRIS OF ANY KIND INCLUDING ICE, SNOW OR FROZEN MATERIAL.
9. THIS DIMENSION IS THE MINIMUM VALUE USED WITH THE 74 FT ANTENNA, FOR THE 112 FT ANTENNA THE MINIMUM DIMENSION WOULD BE 8 FT.
10. WHERE THE SOIL CONDITIONS WARRANT, THEN SULPHUR RESISTANCE CONCRETE SHOULD BE USED.
11. RECOMMEND THE USE OF PLYWOOD AS A TEMPLATE FOR 8 ANCHOR-BOLTS BEFORE PLACEMENT OF CONCRETE.

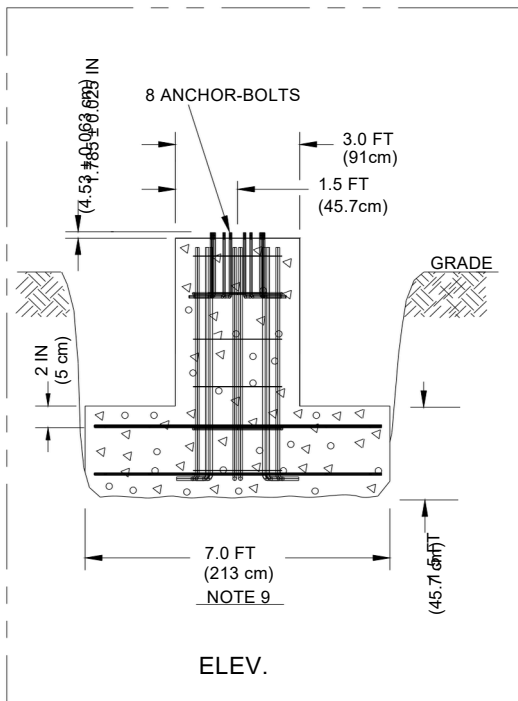

ELEV.

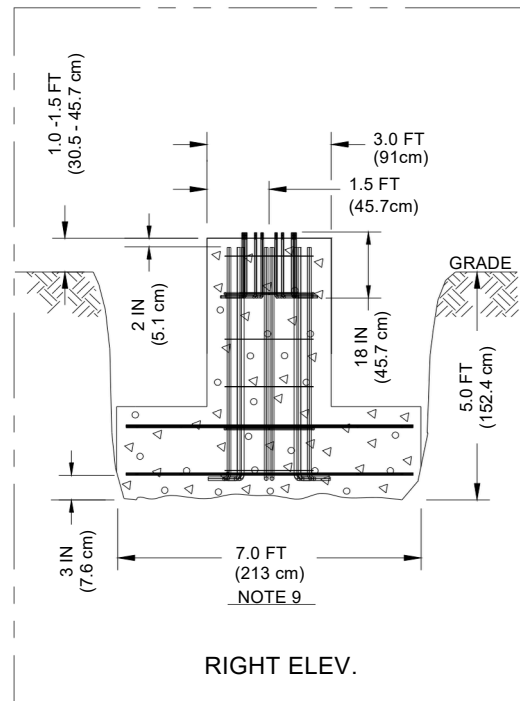

RIGHT ELEV.

FOUNDATION DETAILS FOR VHB-17AM HINGE PLATE OR VTGS-20BH AM STEEL TOWER

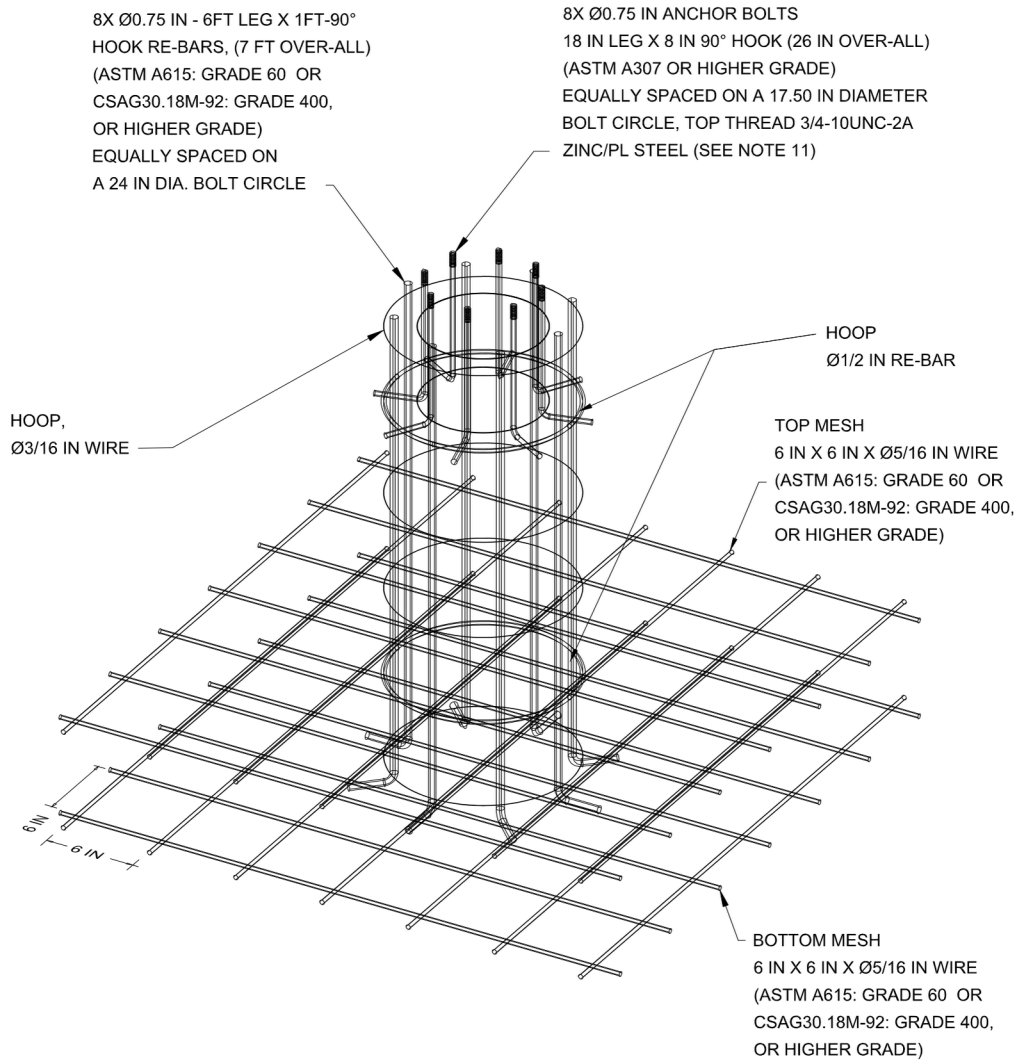

REINFORCING OF CONCRETE



P.O. BOX 603 GUELPH, ONTARIO, CANADA, N1H 6L3
TEL 519-824-3220 FAX 519-824-3411
INTERNET: www.valcom-guelph.com EMAIL: enquiries@valcom-guelph.com

VHB-17AM HINGE PLATE QUICK REFERENCE DATA

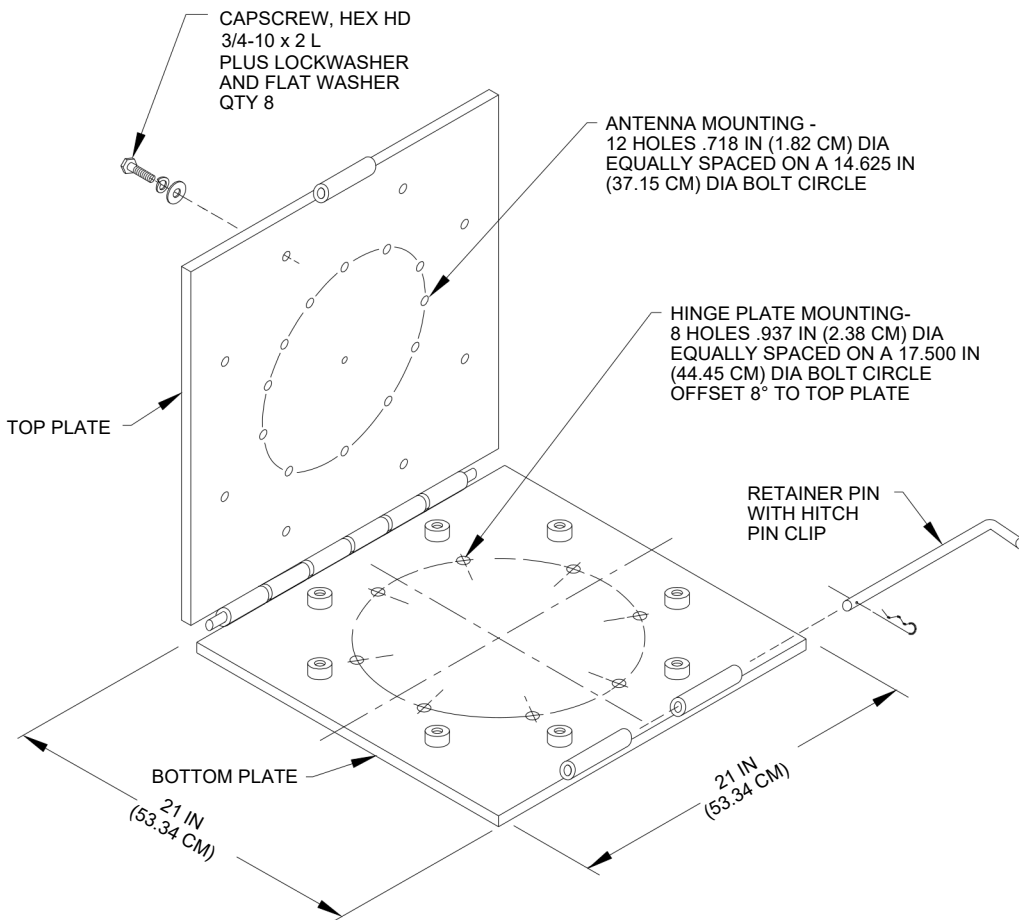

THE FOLLOWING ARE SUPPLIED AS LOOSE ITEMS:

1. CAPSCREW, HEX HD, 5/8-11 X 4 1/4 L, ZINC/PL STEEL, QTY 12
2. FLATWASHER, 5/8 NOM, ZINC/PL STEEL, QTY 24
3. WASHER, LOCK-SPRING, HELICAL, 3/4 NOM, ZINC/PL STEEL, QTY 12
4. NUT, HEX, 3/4-10 UNC, ZINC/PL STEEL, QTY 8



P.O. BOX 603 GUELPH, ONTARIO, CANADA, N1H 6L3
TEL 519-824-3220 FAX 519-824-3411
INTERNET: www.valcom-guelph.com EMAIL: enquiries@valcom-guelph.com

World's Leading Manufacturer Of Fibreglass AM Broadcasting Antennas



SPECIALISTS FOR AM BROADCASTING

VGS-120XXX AM Broadcast Antenna Ground Screen

VALCOM'S VGS-120XXXAM GROUND SCREEN CONSISTS OF 120 RADIALS JOINED TO A CENTER RING AT THE BASE OF THE ANTENNA. THE RING IS PLACED ON A 12 X 12 FOOT COPPER MESH GRID. THE ENDS OF EACH RADIAL ARE TERMINATED BY A 10 FOOT LONG GROUND ROD. THE GROUND SCREEN FEATURES AN ALL COPPER CONSTRUCTION. THE MOUNTING PAD, ANTENNA AND ANTENNA COUPLER ARE FOR REFERENCE ONLY.

IF ENOUGH SPACE IS AVAILABLE, THE GROUND RADIALS SHOULD BE EXTENDED TO THE DISTANCE EQUIVALENT TO A QUARTER WAVELENGTH OF THE OPERATING FREQUENCY.

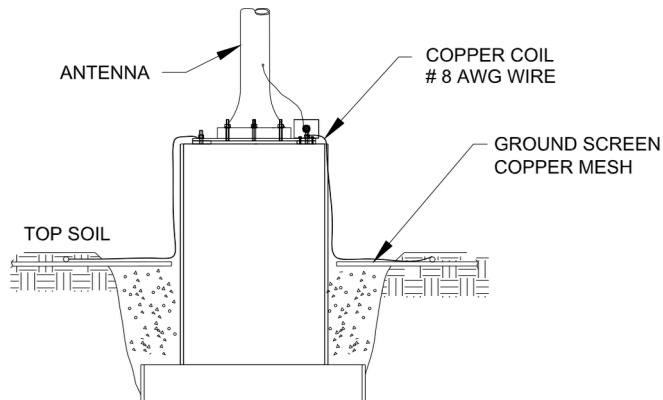

VGS-120XXXAM GROUND SCREEN QUICK REFERENCE DATA

FREQUENCY VS GROUND RADIAL CHART
FOR 1/4-WAVE GROUND PLANE

FREQUENCY (KHz)	RADIAL LENGTH (ft)
540	455.31
600	409.78
700	351.24
800	307.33
900	273.19
1000	245.87
1100	223.52
1200	204.89
1300	189.13
1400	175.62
1500	163.91
1600	153.67
1700	144.63

FOR FREQUENCIES NOT SHOWN IN THIS CHART, USE THE FORMULA BELOW TO CALCULATE THE LENGTH OF THE RADIALS.

QUARTER WAVELENGTH IN FEET:

$$1/4 \lambda = \frac{245.89}{\text{operating frequency (in MHz)}}$$

QUARTER WAVELENGTH IN METERS:

$$1/4 \lambda = \frac{73.48}{\text{operating frequency (in MHz)}}$$

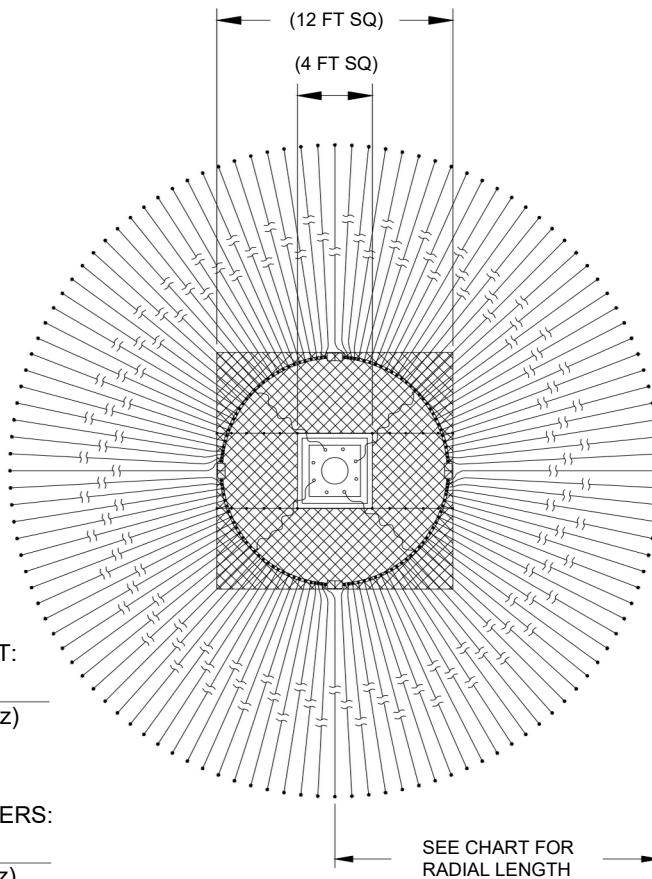

P.O. BOX 603 GUELPH, ONTARIO, CANADA, N1H 6L3
 TEL 519-824-3220 FAX 519-824-3411
 INTERNET: www.valcom-guelph.com EMAIL: enquiries@valcom-guelph.com

V33085AM-CL

THESE DRAWINGS AND SPECS ARE THE PROPERTY OF VALCOM LIMITED AND SHALL NOT BE REPRODUCED, OR USED AS THE BASIS FOR THE MFG OR SALE OF APPARATUS WITHOUT PERMISSION OF VALCOM LTD.													CAD GENERATED DRAWING						
APPLICATION/USAGE					LTR	REVISION				DATE	PREP	CKD	APP						
VGS-120XXXAM AM ANTENNA					A	FIRST ISSUE				-	-	-	-						
					B	IMPROVED GROUND SCREEN				JUNE 2, 2000	J.F.								
					C	IMPROVED GROUND SCREEN FURTHER				AUG. 2, 2000	J.S.								
					D	CHANGED FROM 120 FT TO XXX FT				APR. 26 2004	J.S.								
REV	D	D	D	D															
SHT	1	2	3	4	5	6	7	8	9	10	11	12	13	14	15	16	17	18	19
DESIGN AGENT: VALCOM LIMITED						NSCM/CAOF 35736					VALCOM LIMITED GUELPH, ONTARIO, CANADA								
PREPARED: H. DUONG						TITLE/ TITRE AM ANTENNA GROUND SCREEN INSTALLATION													
CKD/VER:																			
INSPECT/INSPECTE D. BRANDI						DOCUMENT NO. VED-99-0001													
APPVL DATE D'APPROB 25 OCTOBER, 1999						SCALE/ECHELLE N/A		SHEET FEUILLE		1		OF DE		4					

V33085AM-CL

AM Broadcast Antenna Ground Screen Installation

Materials:

- Refer to VGS-120XXXAM (AM Ant. Ground Screen) Brochure
- 3 X 100 feet of #10 AWG copper wire
- Two Different Colours of Spray Paint
- Up to 500 feet of 1/2" Polypropylene Rope
- Brazing Rod and Torch

Pre Installation:

1. Find a suitable area to mark the centre point. There should not be any obstacles within the distance of Point (C). Place a stake firmly in the ground at this centre point, and tie one end of the rope around the stake using a loose knot. This end of the rope will now become point (A).
2. Use the following equation to determine the length of point (B) on the rope. This will be the same as the wavelength of the operating frequency.

$$\text{Point (B)} = \frac{245.89}{\text{operating frequency (in MHz)}}$$

3. Use the following formula to determine the length of point (C) on the rope. This will be the same as the wavelength of the operating frequency plus the arc length between radials.

$$\text{Point (C)} = \text{Point (B)} + (0.0524 \times \text{Point(B)})$$

For example, if operating frequency = 1.0 MHz,
 then Point (B) = 245.89/1.0 = 245.89 ft,
 and Point (C) = 245.89 + (0.0524 x 245.89) = 258.77 ft.

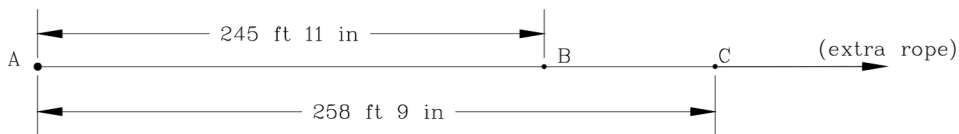

On Site Installation:

3. With the stake firmly placed in the ground and the rope still tied to it, stretch the rope out to point (B) (eg 245.89 ft mark). Make a mark on the ground using the spray paint.
4. Have a person hold the rope at Point (C) (eg 254.77 ft mark) and get them to stand on the first mark that was just painted on the ground.
5. Get the person holding the rope at Point (B) to walk away from the first mark on the ground until both sections of rope are taut. Make a new mark on the ground at this point.

TITLE/ TITRE	AM ANTENNA GROUND SCREEN INSTALLATION	A	DOCUMENT NO VED-99-0001	
DESIGN AGENT:	VALCOM LIMITED	NSCM/CAOF 35736	SCALE/ECHELLE N/A	REV LTR D
		SHEET FEUILLE 2		OF DE 4

V33085AM-CL

AM Broadcast Antenna Ground Screen Installation

6. The person holding the rope at Point (C) should now walk to the new mark on the ground and stand there while the Point (B) person walks away again to mark the next point.
7. Repeat steps 4 to 6 until the first mark is reached again.

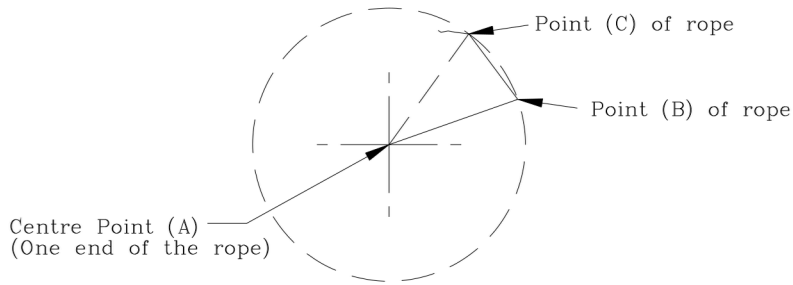

8. You will need to dig holes at each of the marks that have been painted on the ground. The holes should be 2 inches in diameter and 10 feet in depth. A contractor may need to be hired for this operation.
9. The centre point on the ground needs to be excavated so the pouring of the concrete pad can be completed (see Foundation Details for VHB-17AM Hinge Plate/VTGS-20 BH AM Steel Tower).
10. With the concrete pad poured and cured, the three pieces of copper mesh must be tied together.
11. Tie the mesh pieces together every one-inch with the extra #10 copper wire, trying not to overlap the pieces. Once the mesh is tied together, brazing the joints is recommended.

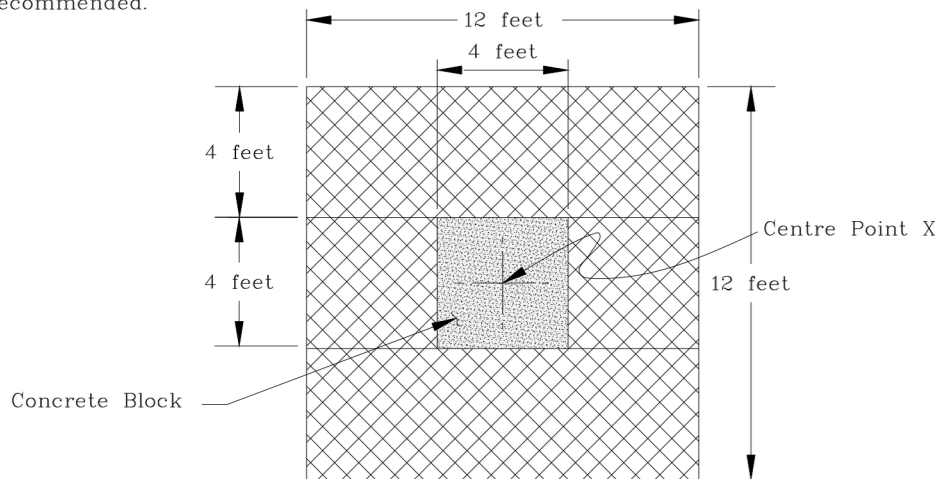

TITLE/ TITRE	AM ANTENNA GROUND SCREEN INSTALLATION	A	DOCUMENT NO VED-99-0001	
DESIGN AGENT:	VALCOM LIMITED	NSCM/CAOF 35736	SCALE/ECHELLE N/A	REV LTR D
			SHEET FEUILLE 3	OF DE 4

V33085AM-CL

AM Broadcast Antenna Ground Screen Installation

12. When brazing the copper mesh is complete, centre the mesh over the centre point of the pad. A space for the concrete block must be cut out of the copper mesh. The average size of the area to cut out is 4 feet x 4 feet but other sizes are acceptable.

13. Clear a 12 foot by 12 foot area around the concrete pad by 3 to 6 inches deep and lay the assembled mesh into the cleared area.

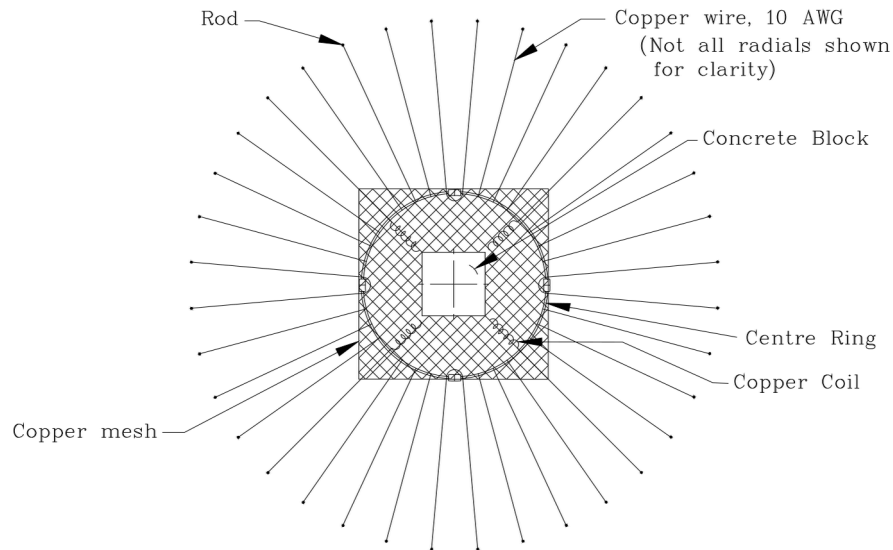

14. The centre ring which should be in four pieces needs to be assembled. The pieces with the coils should be centred over the centre ground pad. Now stretch each copper wire #10 onto each separate copper rod. There should be 120 copper wires attached to 120 copper rods. The part of the copper wire, which is on top of the copper mesh, should be tied and brazed to the copper mesh by using the extra copper wire.

15. Trenches must be dug for each of the 120 copper wire radials. These trenches should be a minimum of 3 inches in depth and any desired width, as long as it is wider than the copper wire. Once again a contractor may need to be used for this duty.

16. After the trenches have been dug, take the ground rod connectors and attach the copper wire to the copper rods. Brazing this connection is recommended. Now drop the rod with the wire attached into the hole for the designated copper rod.

18. Now with everything laid out properly, cover up any exposed ground screen with the excess dirt from digging the holes and trenches and/or fresh topsoil.

Note: The entire installation can also be accomplished by laying all wires and meshing on top of the surface of the ground and covering everything with 3 to 6 inches of fresh topsoil.

TITLE/ TITRE	AM ANTENNA GROUND SCREEN INSTALLATION	A	DOCUMENT NO VED-99-0001		
DESIGN AGENT:	VALCOM LIMITED	NSCM/CAOF 35736	SCALE/ECHELLE N/A	REV LTR D	SHEET FEUILLE 4 OF DE 4