



TECHNICAL MANUAL and INSTALLATION INSTRUCTIONS

V147-CL2 ANTENNA

VTM-04-006B

Valcom Manufacturing Group, Inc.

175 Southgate Drive, P.O. Box 603, Guelph, Ontario, Canada N1H6L3 Tel: 519-824-3220 Fax: 519-824-3411

Web Site: www.valcommfg.ca E-mail: sales@valcomguelph.com

REVISION SHEET

<i>Revision</i>	<i>Description</i>	<i>Date</i>	<i>User</i>
-	Original Issue	November 11, 2004	-
A	Amended Maintenance Section	August 2007	J.Soper
B	Wind speed typo, pg2	October 17, 2008	J.Soper

TABLE OF CONTENTS

<u>Section</u>	<u>Page</u>
1.0 GENERAL INFORMATION.....1	
1.1	Introduction1
1.2	Technical Reference Data.....1
2.0 FUNCTIONAL DESCRIPTION.....3	
2.1	General3
2.2	Electrical Description 3
2.3	Mechanical Description.....3
3.0 MAINTENANCE.....4	
3.1	Scheduled Maintenance.....4
3.2	Corrective Maintenance..... 4
4.0 INSTALLATION.....5	
4.1	Unpacking5
4.2	New Site Preparation.....5
4.3	Assembly and Installation.....5
4.4	Electrical Installation.....6
5.0 PARTS LIST.....8	
5.1	General8
6.0 QUICK REFERENCE DATA.....9	
6.1	General9
6.2	Manufacturer's Address.....9

LIST OF TABLES AND FIGURES

Table 1.1 - Electrical properties of the V147-CL2 Antenna.....1	Table 1.2 - Mechanical properties of the V147-CL2 Antenna.....2
Table 5.1 - List of Parts for the V147-CL2 Antenna..... 8	Figure 4.1 - Gin Pole Arrangement..... 7
Figure 6.1 - Quick Reference Data - V147-CL2 Antenna.....10	Figure 6.2 - Foundation Details For VHB-17 Hinge Plate or VTGS-20BH Steel Tower.....11
Figure 6.3 - Quick Reference Data - VHB-17 Hinge Plate.....12	Figure 6.4 - Quick Reference Data - VTGS-20BH Steel Tower.....13
Figure 6.5 - Quick Reference Data - VGS-36100 Ground Screen.....14	Figure 6.6 - Quick Reference Data - VGS-36100 Ground Screen Installation Instructions....15

1.0 GENERAL INFORMATION

1.1 Introduction

This manual describes the electrical and mechanical properties of the V147-CL2 antenna. It also provides the information necessary to install, operate and maintain the antenna system.

1.2 Technical Reference Data

Table 1.1 - Electrical properties of the V147-CL2 Antenna

<i>Electrical Properties</i>	
<i>Frequency Range</i>	100 kHz to 30 MHz (with capacity of the antenna tuner)
<i>Resonant Frequency</i>	100 kHz to 5000 kHz (as specified by customer)
<i>Power Rating</i>	1 kW PEP
<i>Dry Withstanding Voltage</i>	25 kV
<i>Electrical Length</i>	Varies with Loading Coil Section

Table 1.2 - Mechanical properties of the V147-CL2 Antenna

Mechanical Properties	
3th Section Length	13.0 feet (3.9 meter)
Loading Coil (2nd) Section Length	18.5 feet (5.6 meter)
Bottom Section Length	17.5 feet (5.3 meter)
Typical Assembly Length (including Valcosphere)	49 feet (14.9 meter)
Weight	Approximately 400 lbs (181 kg)
Material	Copper wire and strips embedded in the fiberglass and thermo-setting epoxy resin composite
Finish	Epoxy polyamide paint
Mounting Position	Vertical
Base Diameter	17.5 inches (44.45 cm)
Mounting Hole Diameter	0.718 inches (1.82 cm)
Mounting Holes Dimensions	12 places equally spaced on a 14.625 inch (37.15 cm) diameter bolt circle
Operating Temperature	-76°F to +140°F (-50°C to +65°C)
Wind Loading Test	Up to 180 mph (290 km/hr)
Abrasion Resistance	Very Good
Water Absorption	After 24 hours immersed: 0.2% After 48 hours immersed: 0.6% After 168 hours immersed: 2.0%
Optional Accessories	Top-Hat Whiskers Side-feed or Feed-through base VHB-17 Steel Hinge Plate or VTGS-20BH Steel Tower VGP-17 Gin Pole VGS-36100 Ground Screen

2.0 FUNCTIONAL DESCRIPTION

2.1 General

The V147-CL2 is intended to be used as part of an overall communication system which consists of a transmitter (or receiver or transceiver), an antenna coupler and the antenna. It is used around the world in many applications with requirements in the 100 kHz to 5000 kHz bands for marine and aeronautical radio beacon and, with Top-Hat radials, as a Traveler Information Service (TIS) communication systems.

2.2 Electrical Description

The Valcom, Model V147-CL2 is a field proven, coil loaded, 49-foot antenna. The second section is inductively loaded to a resonant frequency slightly higher than the operating frequency specified by the customer.

2.3 Mechanical Description

Third Section. This is a hollow tapered cylinder made of circumferentially and longitudinally wound fibreglass filaments using a thermosetting epoxy resin matrix. Embedded in the composite are multiple beryllium copper strips laid in a single-turn spiral and secured at the top end to a threaded female ferrule into which the Valcosphere is secured. Depending on the options chosen, there may be up to eight whiskers that thread into the Valcosphere ferrule to form the Top-Hat structure. The surface of the section is smoothed, primed and painted with a polyamide epoxy surface coating.

Coil Loaded Section (Second Section) The coil loaded section is constructed in the same manner as the Third section. The coil is wound using enamel copper wire and is also embedded in the fiberglass. The ends of the coil are braised to the respective ferrules.

Bottom Section. The construction and finish are the same as for the other sections except that the diameter expands out to meet the mounting base. The ferrule is threaded to fit into the bottom of the Coil Loaded section. Multiple parallel conductors are connected to the ferrule at the top and to a conducting ring near the bottom. The feed terminal extends from the bottom ring to the surface of the antenna approximately 18.0 inches from the bottom of the base flange. The base can withstand a flash-over voltage of 25 kV.

NOTE: The sections of the antenna cannot be interchanged with other antennas due to the unique locations of the locking screw holes.

3.0 MAINTENANCE

3.1 *Scheduled Maintenance*

The antenna is virtually maintenance free. The external finish is an epoxy polyamide two part compound paint. The minimum finish life before showing signs of deterioration should be at least six years under normal climate condition.

When used in salt-water environments, it is recommended to wash the antenna base with fresh water to remove any build-up of dried salt residue. This should be performed on a monthly basis or after prolonged exposure to sea-spray.

Use a small wire brush to clear any debris from the drain groove found in the bottom of the antenna base.

3.2 *Corrective Maintenance*

Generally, no corrective maintenance is possible or required. If one section is severely damaged, it must be replaced by a new section. Workshops having experience in handling epoxy fibreglass composite structures may attempt the repair of minor surface damage if practicable.

NOTE

DO NOT USE LEAD BASE PAINT TO TOUCH-UP OR
REPAINT THE ANTENNA. USE ONLY EPOXY BASE PAINT.

4.0 INSTALLATION

4.1 Unpacking

Open the shipping crates and remove the antenna sections. Remove all packing material including the male ferrule protectors on the antenna sections. The V147-CL2 antenna as shipped consists of the items listed in Table 5.1. Check that all of the items are present and in good condition.

4.2 New Site Preparation

- (1) Check to see that the underside of the steel base plate at the site is free of cables and other obstructions.
- (2) Excavate and pour a concrete pad to where the antenna is to be installed (recommended foundation details can be found at the end of this manual).
- (3) Install Ground Screen (recommended ground screen can be found at the end of this manual).

4.3 Assembly and Installation of Antenna on the site

The following steps should be followed to assemble the V147-CL2 antenna (see Figure 4.1).

- (1) Remove retainer pin on the hinge plate and open top plate to 90°, mount the bottom plate of the hinge plate on the anchor bolts. Secure with hardware (flat washer, lockwasher, and nut) on each bolt.
- (2) Obtain four to six saw horses or other supports that will hold the complete antenna horizontally at a convenient working height and place them in the assembly area. The assembly area must be a cleared working space approximately 55 feet long and 20 feet wide.
- (3) Support the base section (item 1, Table 5.1) on two of the saw horses.
- (4) Align mounting holes in the plate with holes of the antenna flange and gin pole adapter, secure base section to the plate with hardware, fed through from underside.
- (5) Tie a rope (1/2" diameter polypropylene) to the eye of the gin pole, then slide the

- gin pole into the pipe attachment and secure.
- (6) Support the second section (item 2, Table 5.1) on two other saw horses so that the two sections lie in the same straight line.
 - (7) Make sure the threads of the male ferrule on the base section are clear of foreign material and free of burrs.
 - (8) Assemble the second antenna section onto the base section and tighten to align the arrows at the joint using the strap wrench supplied (item 6, Table 5.1). Install the setscrews and seal with the sealant provided (items 7 and 8, Table 5.1).
 - (9) Assemble the third section (item 3, Table 5.1) to the second section by repeating steps 6 to 8.
 - (10) After all sections are assembled, assemble the Valcosphere (item 4, Table 5.1) to the top of the third section. Install the setscrews provided (item 8, Table 5.1).
 - (11) If the antenna was ordered with a Top-Hat, install and tighten the 8 Whiskers (item 5, Table 5.1) into the threaded holes found below the Valcosphere.
 - (12) The antenna now is ready to raise to its final position.
 - (13) Tie the rope (from gin pole eye) to a point about halfway up the second section (see Figure 4.1). A timber hitch knot is recommended.
 - (14) Erect antenna by applying a gradual and constant pull on the rope referred to as the “Pulling Force” (a winch or vehicle is recommended).
 - (15) Once the antenna is in the vertical position, insert retainer pin back into hinge plate, secure with tension pin. Use bolts (supplied) to secure upper and lower plates of the hinge plate together.
 - (16) Remove the gin pole. Electrical connections can now be made.

4.4 *Electrical Installation*

Very carefully secure the lead from the transmitter, transceiver or coupler to the antenna feedpoint. Depending on the options chosen during purchase, the feedpoint may be an acorn screw and lock-washer located approximately 18 inches up from the base or it may be a threaded post out the bottom of the antenna.

GIN POLE ARRANGEMENT
FOR V147 SERIES ANTENNA

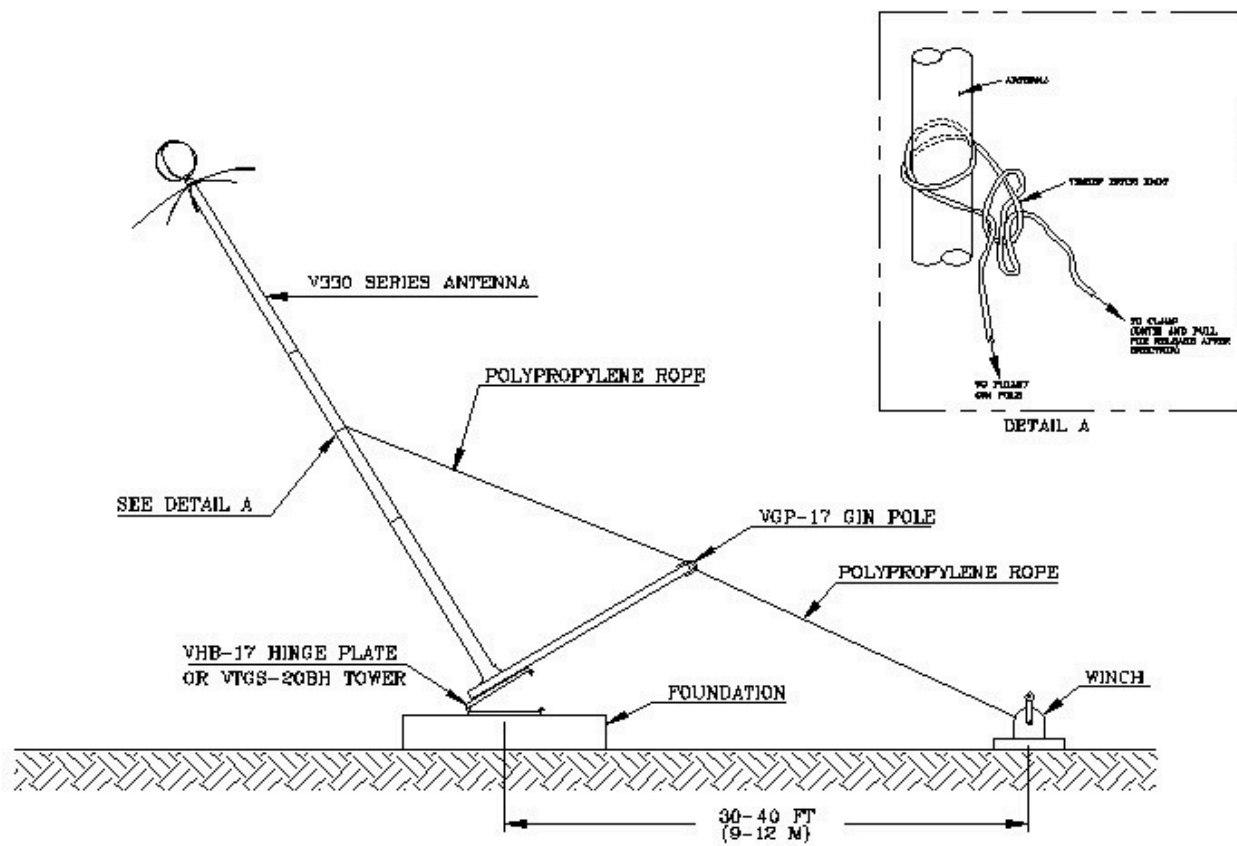

Figure 4.1

82703
REV --

5.0 PARTS LIST

5.1 General

A list of parts shipped with the V147-CL2 antenna appears in Table 5.1.

Table 5.1 - List of Parts for the V147-CL2 Antenna

<i>Item No.</i>	<i>Part Number</i>	<i>Description</i>	<i>Qty</i>	<i>Notes</i>
1	VD-00-00264	Base Section	1	
2	VD-00-00265	Section 2 (Coil Loaded)	1	
3	VD-00-00266	Section 3 (Strap Only)	1	
4	VD-77-00132	Valcosphere	1	
5	VC-84-00024	Top-Hat Whiskers	8	Optional
6		Strap Wrench	1 ea	
7		Silicone Sealant	1	
8		Hardware Package (Lockwasher, Hex-socket setscrews)	1 set	

6.0 QUICK REFERENCE DATA

6.1 General

Quick reference engineering data for use during planning and installation activities for the V147-CL2 antenna is presented on the following page.

- C Quick Reference Data - V147-CL2 Antenna
- C Foundation Details For VHB-17 Hinge Plate or VTGS-20BH Steel Tower
- C Quick Reference Data - VHB-17 Hinge Plate
- C Quick Reference Data - VTGS-20BH Steel Tower

6.2 Manufacturer's Address

<i>Postal address:</i>
Valcom Manufacturing Group, Inc. P.O. Box 603 Guelph, Ontario Canada N1H 6L3

<i>Shipping address:</i>
Valcom Manufacturing Group, Inc. 175 Southgate Drive Hanlon Industrial Park Guelph, Ontario Canada N1G 3M5

QUICK REFERENCE DATA V-147-CL2-TH

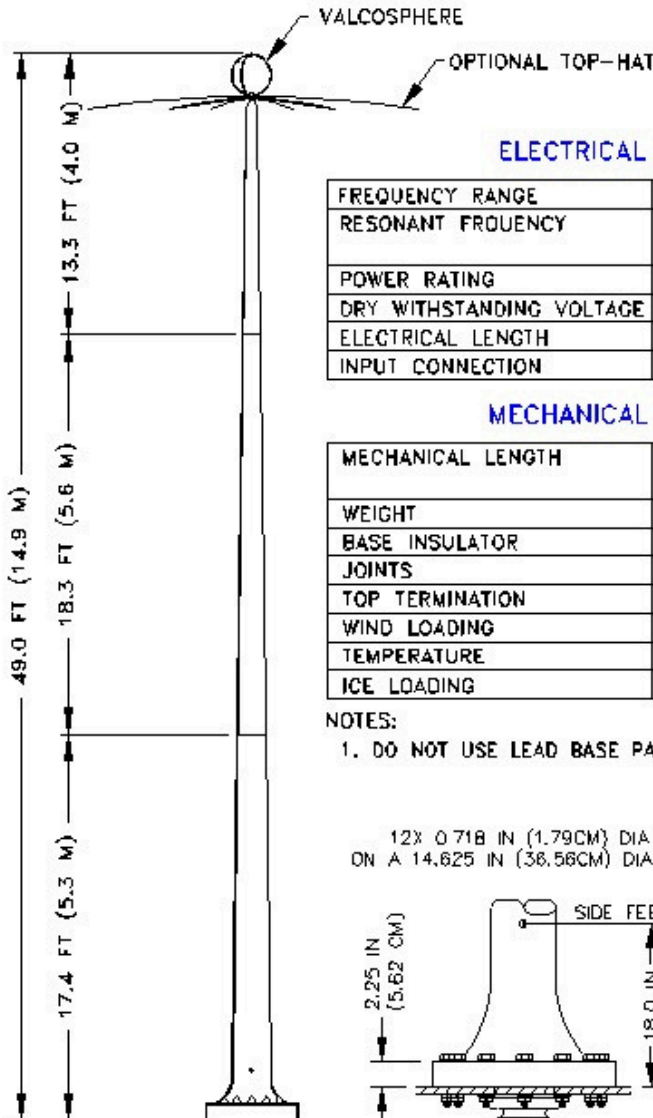

ELECTRICAL CHARACTERISTICS

FREQUENCY RANGE	100 KHZ TO 30 MHZ- WITH TUNER
RESONANT FROQUENCY	100 KHZ TO 4.5 MHZ (AS SPECIFIED BY CUSTOMER)
POWER RATING	1.0 KW AVERAGE 4.0 KW PEP
DRY WITHSTANDING VOLTAGE	25 KV
ELECTRICAL LENGTH	VARIABLES WITH LOADING SECTION
INPUT CONNECTION	3/8-24 BOLT (SIDE OR BOTTOM)

MECHANICAL CHARACTERISITICS

MECHANICAL LENGTH	49 FT (14.9 M) TYPICAL (OTHER HEIGHTS AVAILABLE UPON REQUEST)
WEIGHT	400 LBS (181.4 KG)
BASE INSULATOR	EPOXY FIBREGLASS
JOINTS	BRONZE THREADS WITH LOCKING PINS
TOP TERMINATION	VALCOSPHERE AND TOP-HAT
WIND LOADING	180 MPH (288 KM/HR)
TEMPERATURE	-60°F to 150°F (-50°C to 65°C)
ICE LOADING	0.75 IN (1.9 CM) ICE AT 100 MPH (160 KM/H)

NOTES:

- DO NOT USE LEAD BASE PAINT TO TOUCH-UP OR REPAINT ANTENNA

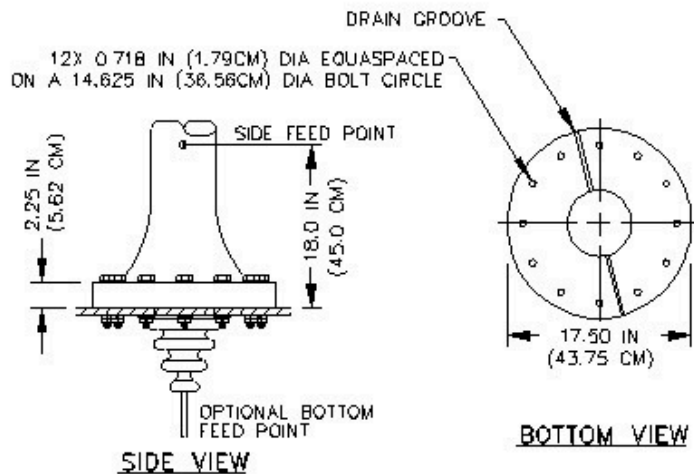

P.O. BOX 603 GUELPH, ONTARIO, CANADA, N1H 6L3
 TEL 519-824-3220 FAX 519-824-3411
 INTERNET: www.valcom-guelph.com EMAIL: enquiries@valcom-guelph.com

FOUNDATION DETAILS FOR VHB-17 HINGE PLATE OR VTGS-20BH STEEL TOWER

6 X ANCHOR-BOLTS (REF. ONLY)
EQ.SP.D ON A 14.625 IN (37.2 cm)
DIAMETER BOLT CIRCLE

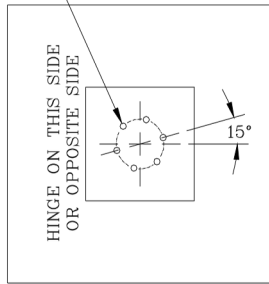

PLAN VIEW

NOTES:

1. FOUNDATION BASE TO BE ON UNDISTURBED SOIL.
2. FOUNDATION EXCAVATION MUST BE FREE OF WATER BEFORE PLACEMENT OF CONCRETE.
3. DURING PLACEMENT OF CONCRETE, MAXIMUM FREE FALL DISTANCE SHALL NOT EXCEED FOUR FEET (120cm)
4. ALL CONCRETE PLACED DURING FREEZING TEMPERATURES SHALL BE PRE-HEATED AND PROPERLY PROTECTED DURING CURING. ALL HANDLING AND PLACEMENT TO BE IN ACCORDANCE WITH GOOD CONSTRUCTION PRACTICE.
5. MINIMUM 28 DAY COMPRESSIVE STRENGTH-3,000 PSI
6. AIR ENTRAINED CONCRETE 6% ± 1
7. SLUMP RANGE OF CONCRETE DURING PLACEMENT, 1.5 TO 4.5 INCHES (3.7 TO 11.2cm).
8. BACKFILL MATERIAL SHALL BE FREE FROM DEBRIS OF ANY KIND INCLUDING ICE, SNOW OR FROZEN MATERIAL.
9. THIS DIMENSION IS THE MINIMUM VALUE USED WITH THE 74 FT ANTENNA. FOR THE 112 FT ANTENNA THE MINIMUM DIMENSION WOULD BE 8 FT.
10. WHERE THE SOIL CONDITIONS WARRANT, THEN SULPHUR RESISTANCE CONCRETE SHOULD BE USED.
11. RECOMMEND THE USE OF PLYWOOD AS A TEMPLATE FOR 6 ANCHOR-BOLTS BEFORE PLACEMENT OF CONCRETE.

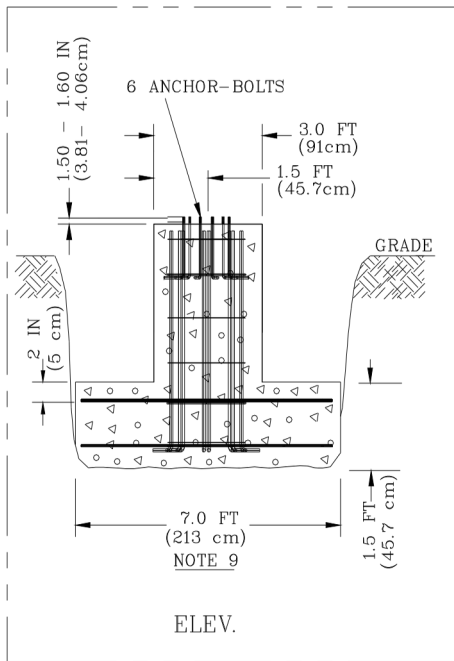

ELEV.

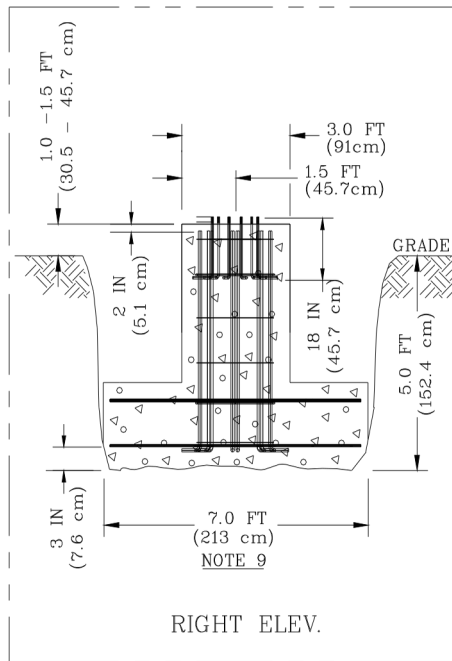

RIGHT ELEV.

SP115
REV: C

SHEET 1 OF 2

Figure 6.2

VHB-17 HINGE PLATE QUICK REFERENCE DATA

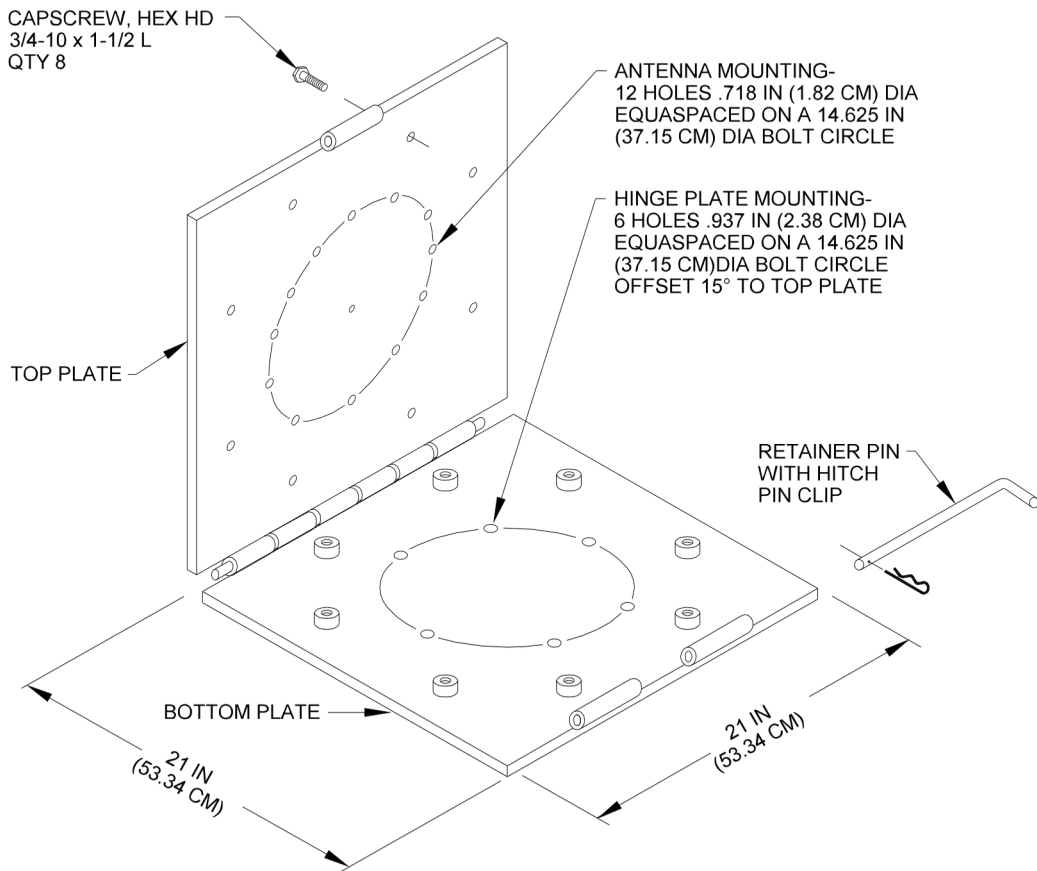

THE FOLLOWING ARE SUPPLIED AS LOOSE ITEMS:

1. CAPSCREW, HEX HD, 5/8-11 X 4 L, ZINC/PL STEEL, QTY 12
2. FLATWASHER, 5/8 NOM, ZINC/PL STEEL, QTY 24
3. WASHER, LOCK-SPRING, HELICAL, 5/8 NOM, ZINC/PL STEEL, QTY 12
4. NUT, HEX, 5/8-11, ZINC/PL STEEL, QTY 12



P.O. BOX 603 GUELPH, ONTARIO, CANADA, N1H 6L3
TEL 519-824-3220 FAX 519-824-3411
INTERNET: www.valcom-guelph.com EMAIL: enquiries@valcom-guelph.com

Figure 6.3

VTGS-20BH QUICK REFERENCE DATA

VTGS-20BH IS THE STANDARD MODEL NUMBER FOR VALCOM'S HEAVY DUTY STEEL HINGED TOWER. THE ANTENNA MOUNTING PLATE COMES IN FOUR DIFFERENT CONFIGURATIONS AS SHOWN BELOW. SUBSTITUTE "X" IN THE MODEL NUMBER FOR THE MOUNTING PLATE THAT IS REQUIRED. SUBSTITUTE "Y" IN THE MODEL NUMBER FOR THE HEIGHT OF TOWER REQUIRED IN 2 FOOT INCREMENTS. UNLESS OTHERWISE SPECIFIED THE STANDARD NOMINAL HEIGHT IS EIGHT FEET (2.44 M)

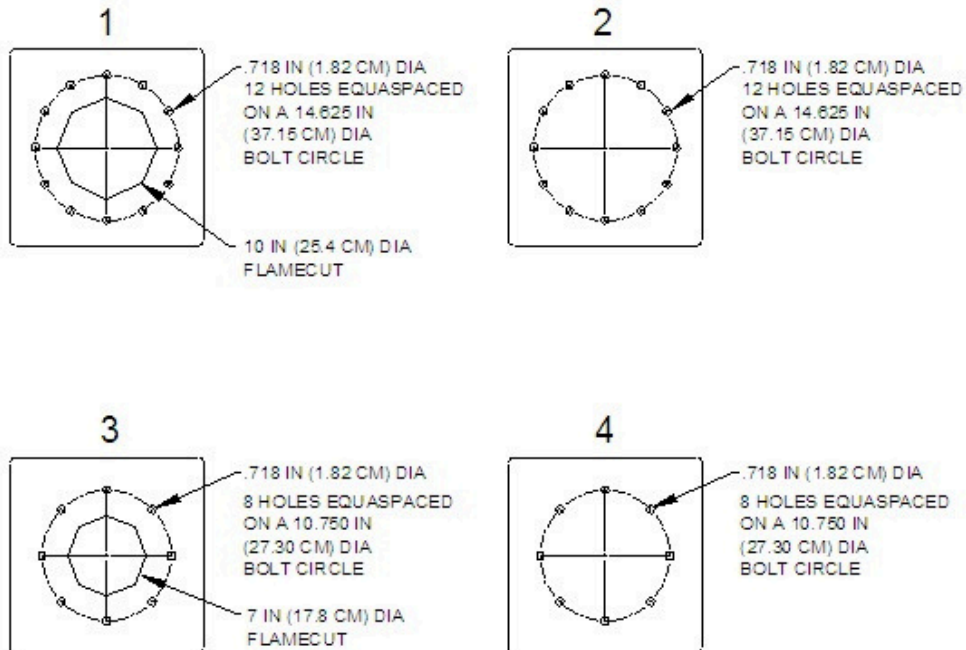
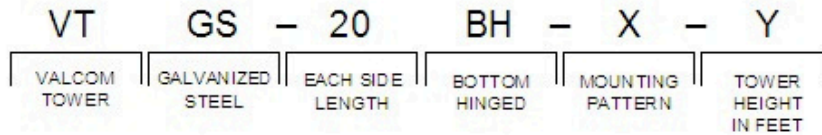

P.O. BOX 603 GUELPH, ONTARIO, CANADA, N1H 6L3
TEL 519-824-3220 FAX 519-824-3411
INTERNET: www.valcom-guelph.com EMAIL: enquiries@valcom-guelph.com

Figure 6.4

VGS-36100 GROUND SCREEN
QUICK REFERENCE DATA

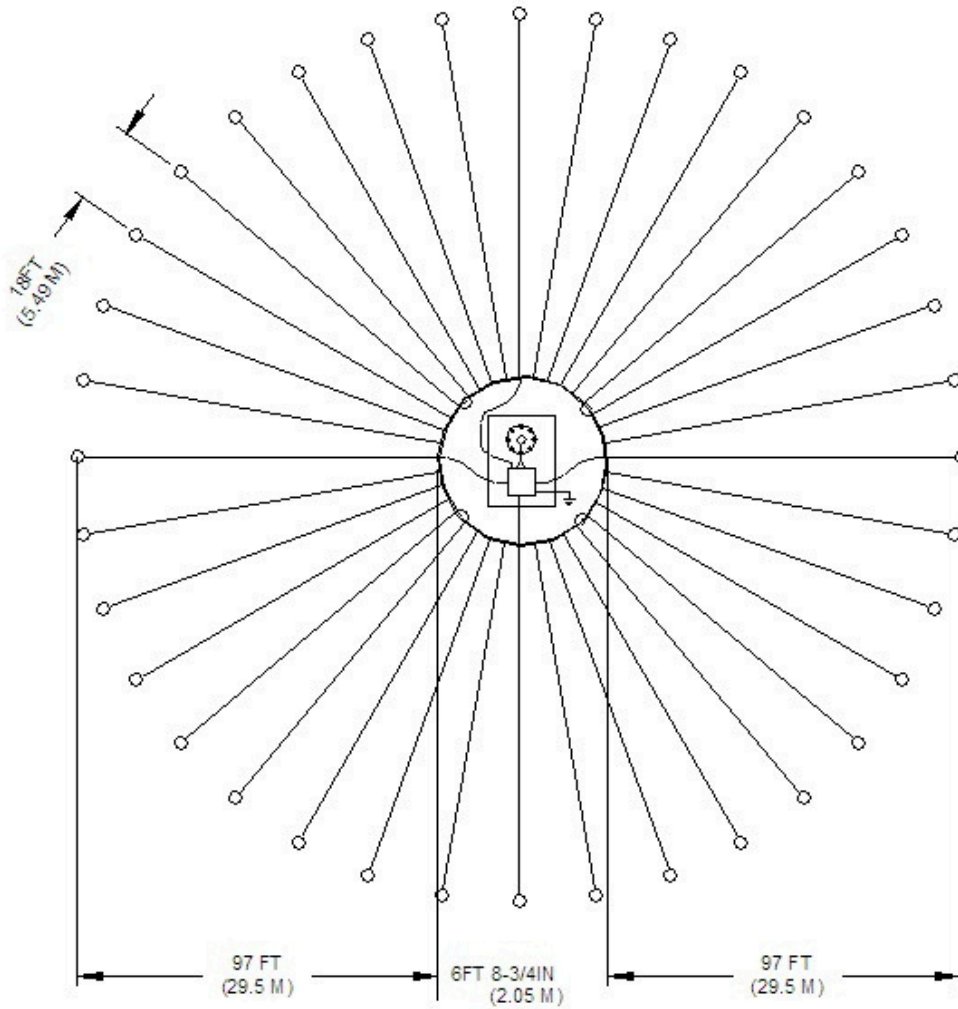

P.O. BOX 603 GUELPH, ONTARIO, CANADA, N1H 6L3
TEL 519-824-3220 FAX 519-824-3411
INTERNET: www.valcom-guelph.com E MAIL: enquiries@valcom-guelph.com

Figure 6.5

89-214
REV. 2

VGS-36100 GROUND SCREEN INSTALLATION INSTRUCTIONS

PARTS LIST

1. GROUND RADIAL
2. CENTRE RING
3. COMPRESSION UNION
4. JUMPER WIRE
5. GROUND ROD
6. GROUND ROD CONNECTOR
7. CONNECTING WIRE

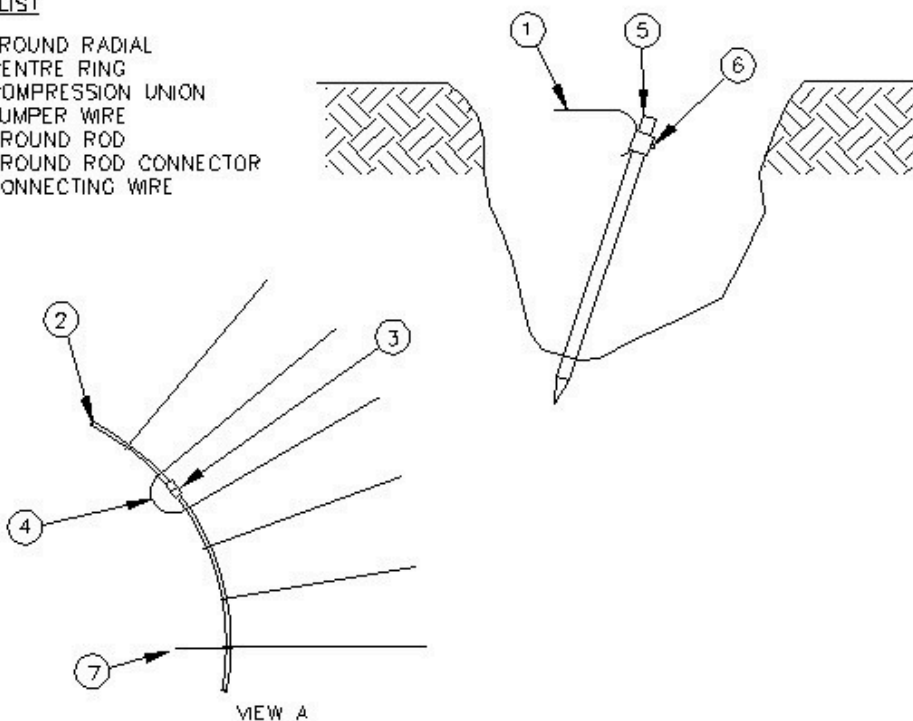

ASSEMBLY AND INSTALLATION INSTRUCTIONS

1. DIG AN 18 INCH DEEP TRENCH CENTRALLY AROUND THE ANTENNA PAD WITH A DIAMETER OF APPROXIMATELY 7 FEET.
2. DIG 4 TRENCHES 18 INCHES DEEP FROM THE CENTRE RING TO THE ANTENNA PAD 90° APART.
3. DIG 36 STRAIGHT TRENCHES 18 INCHES DEEP, 97 FEET LONG RADIALLY FROM THE CENTRE RING THE RADIALS SHOULD BE EQUALLY SPACED 18 FEET APART AT THE OUTER ENDS
4. FILL ALL THE TRENCHES WITH 6 INCHES OF ROCK FREE SOIL.
5. ENCIRCLE ANTENNA WITH FOUR SECTORS OF THE CENTRE RING. FLEXIBLE TUBING SHOULD BE FORMED SO THAT THE ANTENNA IS APPROXIMATELY AT THE CENTRE OF THE RING.
6. JOIN THE FOUR SECTMENTS OF THE CENTRE RING WITH THE COMPRESSION UNIONS. CONNECT THE 12 INCH JUMPER WIRES ACROSS THE UNIONS AND BRAZE THE FREE END ONTO THE COPPER CENTRE RING TUBING.
7. DEPLOY THE 36 GROUND RADIALS IN THE TRENCHES AND SECURE TO THE GROUND RODS WITH THE GROUND ROD CONNECTORS. USING A SLEDGE HAMMER, DRIVE THE RODS INTO THE GROUND.
8. CUT THE FOUR CONNECTING WIRES TO LENGTH AND TERMINATE AT GROUND STUDS ON TUNER. IF A SUPPORT TOWER IS USED, TERMINATE WIRES TO MOUNTING STUDS ON CONCRETE PAD.
9. COVER THE CONNECTING WIRE, CENTRE RING AND GROUND RADIALS WITH 6 INCHES OF ROCK FREE SOIL. BACKFILL REMAINDER OF TRENCH WITH THE REMOVED SOIL.

Figure 6.6