



TECHNICAL MANUAL and INSTALLATION INSTRUCTIONS

VBBA-NVIS ANTENNA SYSTEM

VTM-06-005 - Rev D

Valcom Manufacturing Group, Inc.

175 Southgate Drive, P.O. Box 603, Guelph, Ontario, Canada N1H 6L3 Tel: 519-824-3220 Fax: 519-824-3411

Web Site: www.valcommfg.ca E-mail: sales@valcomguelph.com

VBBA-NVIS Antenna System

REVISION SHEET

Revision	Description	Date
-	Original Issue	November 8, 2006
A	Added generalized info for shipboard installations	July 8, 2009
B	- Fixed dimension error on foundation details from 228.5" to 240.5" - Adjusted overall dimensions from 29' to 31'	September 30, 2010
C	- Changed anti-seize and added silicone sealant	October 4, 2013
D	- Fixed part numbers on pg 2 - Edited reference data on pg 22	February 25, 2019

VBBA-NVIS Antenna System

TABLE OF CONTENTS

Section	Page
1.0 GENERAL INFORMATION.....	1
1.1 Introduction	1
1.2 Safety Precautions	1
2.0 PARTS LIST	2
3.0 VBBA-NVIS ANTENNA SYSTEM.....	4
3.1 General Description	4
3.2 Electrical Description	4
3.3 Mechanical Description	4
4.0 INSTALLATION DETAILS	6
4.1 Unpacking	6
4.2 Foundation	6
4.3 Antenna and Structure Assembly	6
4.4 Ground Screen	17
5.0 SYSTEM TUNING AND CONNECTION	18
5.1 Tuning	18
5.2 Electrical Connections	18
5.3 Testing	18
6.0 OPERATIONAL GUIDELINES.....	20
6.1 General	20
6.2 Local Surface Wave Comms	20
6.3 NVIS Comms	20
7.0 MAINTENANCE.....	21
7.1 Scheduled Maintenance	21
7.2 Corrective Maintenance.....	21
8.0 ADDITIONAL REFERENCE DATA.....	22
8.1 Contact Information.....	22
8.2 Associated Components.....	22
- Recommended Foundation Details	23
-Ground Screen Layout	25
-Theoretical Radiation Plots	26

VBBA-NVIS Antenna System

LIST OF TABLES AND FIGURES

Figure 2-1 - Description of Hardware Kit (Item 21, Table 2-1).....	3
Figure 2-2 - Description of Ground Screen Kit (Item 25, Table 2-1).....	3
Figure 3-1 - Assembled VBBA-NVIS Antenna System.....	5
Figure 4-1 - Typical Hardware Assembly Order.....	6
Figure 4-2 - Assembly Steps 1 and 2.....	7
Figure 4-3 - Assembly Step 3.....	7
Figure 4-4 - Assembly Steps 4 and 5.....	8
Figure 4-5 - Assembly Step 6.....	8
Figure 4-6 - Assembly Step 7.....	9
Figure 4-7 - Assembly Steps 8 and 9.....	10
Figure 4-8 - Assembly Step 10.....	11
Figure 4-9 - Assembly Step 11.....	12
Figure 4-10 - Assembly Step 12.....	12
Figure 4-11 - Assembly Step 13.....	13
Figure 4-12 - Assembly Step 14.....	14
Figure 4-13 - Assembly Steps 15 and 16.....	15
Figure 4-14 - Assembly Steps 18 and 19.....	16
Figure 5-1 - Typical VSWR Response of the VBBA-NVIS Antenna System.....	19

Table 2-1 - VBBA-NVIS Antenna System Parts List.....	2
Table 3-1 - Electrical Specifications for the VBBA-NVIS Antenna.....	4
Table 3-2 - Mechanical Specifications for the VBBA-NVIS Antenna.....	5

VBBA-NVIS Antenna System

1.0 GENERAL INFORMATION

1.1 Introduction

This manual describes the electrical and mechanical properties of the VBBA-NVIS Antenna System. This manual also provides the information necessary to install, operate and maintain the system. A suggested site layout is shown in Figure 1-1.

1.2 Safety Precautions

The following general safety precautions are not related to any specific procedures and therefore do not appear elsewhere in this publication. These are recommended precautions that personnel must understand and apply during many phases of operation and maintenance.

WARNING

Keep away from live circuits.
Operating personnel must at all times observe all safety regulations,
to prevent serious injury or death due to electrical shock.

Do not service or adjust alone.
Under no circumstances should any person service or adjust the equipment,
except in the presence of someone who is capable of rendering aid.

Personnel working with or near high voltages should be familiar with modern
methods of resuscitation.

WARNING

Ensure that the transmitting equipment is de-energized prior to inspection of the antenna.
Make sure the test equipment is properly grounded to prevent electric shock.

CAUTION

Make sure the antenna is properly supported before removing its mounting hardware.

WARNING

Do not coat the insulator with any substance; do not paint with lead base paints.

VBBA-NVIS Antenna System

2.0 PARTS LIST

Table 2-1 - VBBA-NVIS Antenna System Parts List

Item #	Part Number	Description	Qty
1	VD-06-00092-1	Antenna Base Section	1
2	VD-06-00096-1	Antenna Sleeve Adapter	1
3	VC-06-00099-1	Antenna Whip Section	2*
4	VD-06-00104-1	Structural Leg, Joint Side, Left	1
5	VD-06-00104-2	Structural Leg, Joint Side, Right	1
6	VD-06-00104-3	Structural Leg, Base Side, Left	1
7	VD-06-00104-4	Structural Leg, Base Side, Right	1
8	VD-06-00103-1	Structural Leg, Base Side, Angle	1
9	VD-06-00105-1	Structural Cross Member	1
10	VD-06-00108-1	Mounting Plate, Base Side, Back	1
11	VD-06-00108-2	Mounting Plate, Base Side, Front	1
12	VD-06-00108-3	Mounting Plate, Joint Side, Back	1
13	VD-06-00108-4	Mounting Plate, Joint Side, Front	1
14	VD-06-00106-1	Clip, Main Leg, Inside	4
15	VD-06-00106-2	Clip, Main Leg, Outside	4
16	VD-06-00111-1	Clip, Angle, Upper, Left	1
17	VD-06-00111-2	Clip, Angle, Upper, Right	1
18	VD-06-00107-1	Clip, Angle, Lower, Left	1
19	VD-06-00107-2	Clip, Angle, Lower, Right	1
20	VC-06-00102-1	Backing Plate	1
21	VC-06-00094-1	Hardware Kit (See figure 2-1)	1
22	MIL-A-907E	Anti-Seize Compound	1
23	262 VB-06-	Thread Lock Compound	1
24	00171-1 VD-	Feedline	1*
25	06-00114-1	Ground Screen Kit (See Figure 2-2)	1*
26	VTM-06-005	Technical Manual	1
27		Silicone Sealant	1

* May not be delivered with all systems.

VBBA-NVIS Antenna System

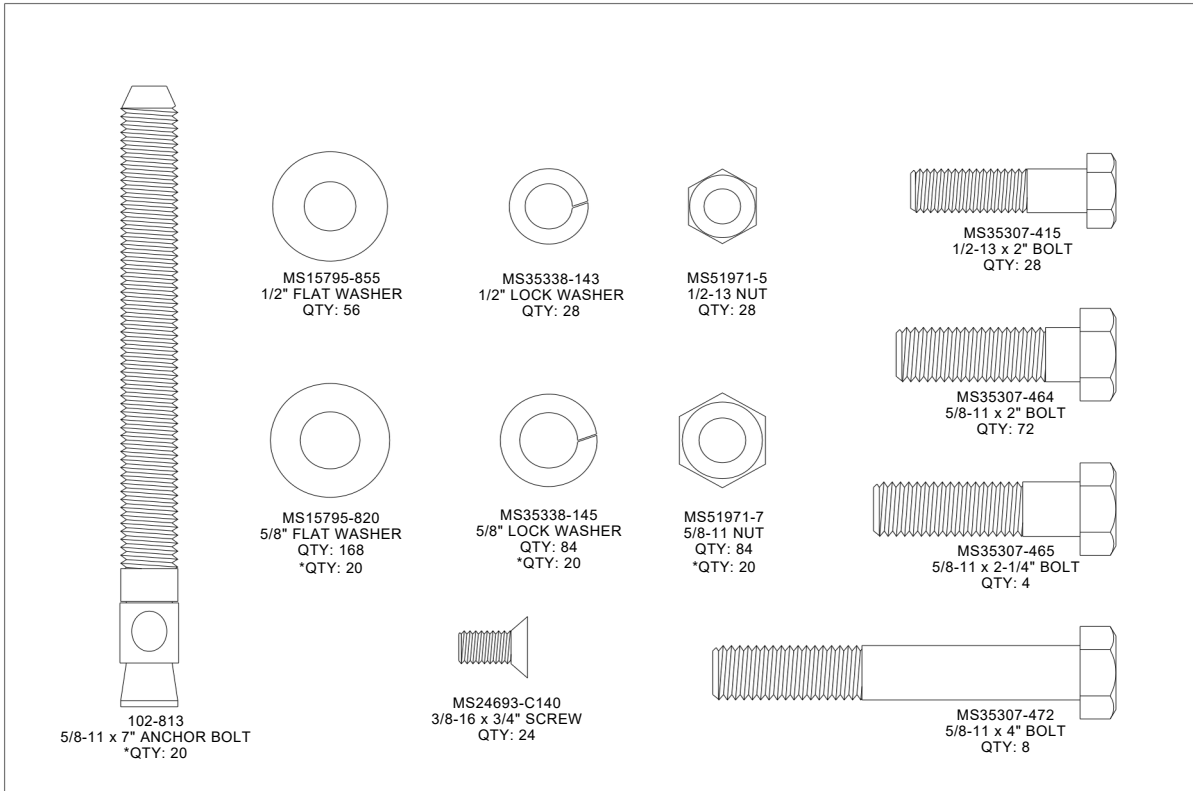

Figure 2-1 Description of Hardware Kit (Item 21, Table 2-1)
*Items not supplied with shipboard installation

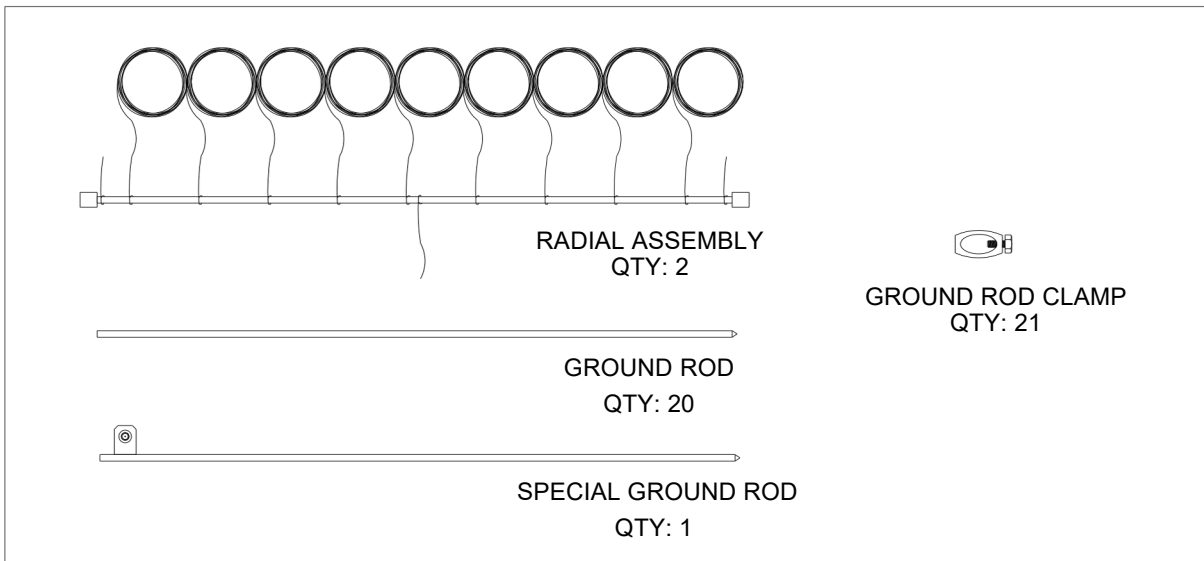

Figure 2-2 Description of Ground Screen Kit (Item 25, Table 2-1)
Not included with shipboard installation

VBBA-NVIS Antenna System

3.0 VBBA-NVIS ANTENNA SYSTEM

3.1 General Description

The Valcom Model VBBA-NVIS antenna is a horizontally installed broadband HF antenna designed specifically for Near Vertical Incident Skywave (NVIS) operation. It is intended to be used as part of an overall communication system which consists of a transmitter (or receiver or transceiver) and the antenna. A vertical whip option can be utilized to improve local ground wave propagation as well.

3.2 Electrical Description

The VBBA-NVIS antenna is normally employed as an end-fed horizontal whip antenna. The antenna employs patented techniques to match the input impedance to 50 ohms. The antenna exhibits a near omni-directional radiation pattern in the azimuth plane with maximum gain at around 90° elevation. The antenna can handle up to 3 kW of input power.

Table 3-1 - Electrical Specifications for the VBBA-NVIS Antenna

Frequency Range	2 MHz to 30 MHz
NVIS Frequency Range	3 MHz to 15 MHz
VSWR	< 3:1 across the full band
Polarization	Horizontal and Vertical
Power Rating	up to 3 kW
Dry Withstanding Voltage	30 kV

3.3 Mechanical Description

The antenna base section is made of a hollow tapered aluminum tube bonded to a fiberglass insulating flange mount. The base section attaches to an adapter which allows installation of the top whip(s). The standard configuration is a single horizontal whip. An optional configuration is a second vertical whip installed at the adapter joint.

The top whips are also made of hollow tapered aluminum tubes. One tube installs horizontally and one tube installs vertically.

The entire antenna is supported 8 to 12 ft off the ground with a fiberglass H-beam support structure. The structure needs to be anchored to the ground with either anchor bolts in concrete pads or bolted to a reinforced shipdeck.

VBBA-NVIS Antenna System

Table 3-2 -Mechanical Specifications for the VBBA-NVIS Antenna

Assembled Dimensions (with vertical option)	31ftx5ftx10ft(9.4m x 1.5m x 3.0m) 31ftx5ftx20ft(9.4m x 1.5m x 6.1m)
Weight	Approximately 600lbs (272 kg) overall
Construction Materials	Aluminum, Fibreglass and Stainless Steel
Finish	Grey silicone alkyd paint
Mounting Position	Horizontal
Storage Temperature	-67°F to +158°F (-55°C to +70°C)
Operating Temperature	5°F to +149°F (-15°C to +65°C)
Wind Loading Test	Upto 170mph (272km/hr) relative
Abrasion Resistance	Very Good
Humidity	0 - 100%

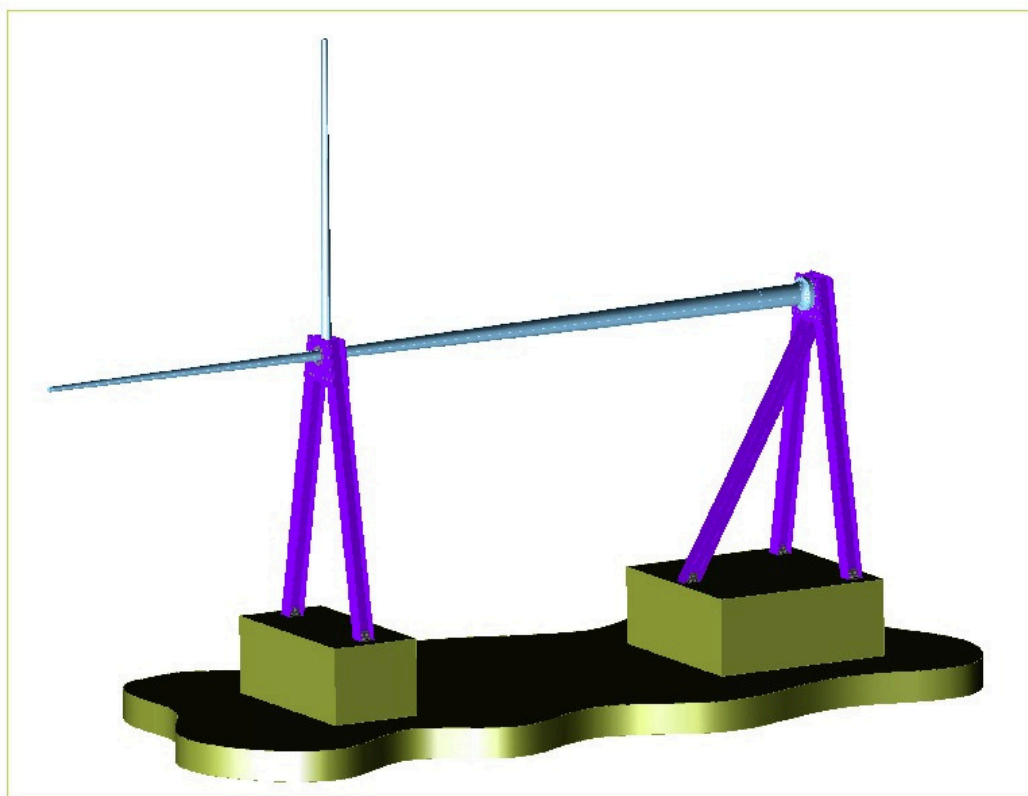

Figure 3-1 Assembled VBBA-NVIS Antenna System

VBBA-NVIS Antenna System

4.0 INSTALLATION DETAILS

4.1 Unpacking

Open the shipping crates and remove the antenna sections, hardware kit, clip kit and structure parts. It is recommended not to remove packing material until ready to assemble the parts together. The VBBA-NVIS antenna, as shipped, consists of the items listed in Table 2-1. Check that all of the items are present and in good condition.

4.2 Foundation

If erecting on land:

- (1a) Excavate and pour concrete pads in accordance with local standards. A recommended foundation layout is detailed in Section 8.0 of this manual. It is essential that the two pads are perfectly level with each other.
- (2a) Drill the anchor bolt holes with a 5/8" concrete drill bit to the depth shown in the concrete foundation details. Accurate location of the anchor bolt holes is crucial for smooth assembly of the system. Remove all dust and debris from the holes. Install the 20 anchor bolts (Part of Item 20, Table 2-1) loosely in the holes.

If erecting on ship:

- (1b) Build reinforced platforms on the ship deck to mimic the effective height above the ground as shown in the Concrete foundation details in Section 8.0.
- (2b) Drill clearance holes for 5/8" bolts or weld 5/8" threaded rods to the ship foundation platforms. Accurate location of the anchor bolt holes is crucial for smooth assembly of the system. Remove all fillings and debris from the holes and use adequate rust-prevention methods.

4.3 Antenna and Structure Assembly

Figure 4-1 Hardware assembly order for all bolt connections, unless otherwise stated.

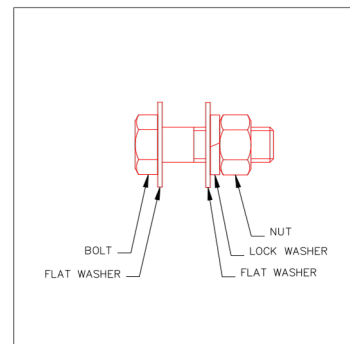

VBBA-NVIS Antenna System

- (1) Lay the left and right “base side” legs (Items 6 and 7, Table 2-1) on the ground with the notched corner upwards and inwards.
- (2) Place the front “base side” plate (Item 11, Table 2-1) on top of the legs and loosely fasten the ten outside 5/8" x 2" bolts. Refer to Figures 4-1 and 4-2.
- (3) Flip the assy over and place the back “base side” plate (Item 10, Table 2-1) on top of the legs and loosely fasten all sixteen 5/8" x 2" bolts. Refer to Figure 4-3.

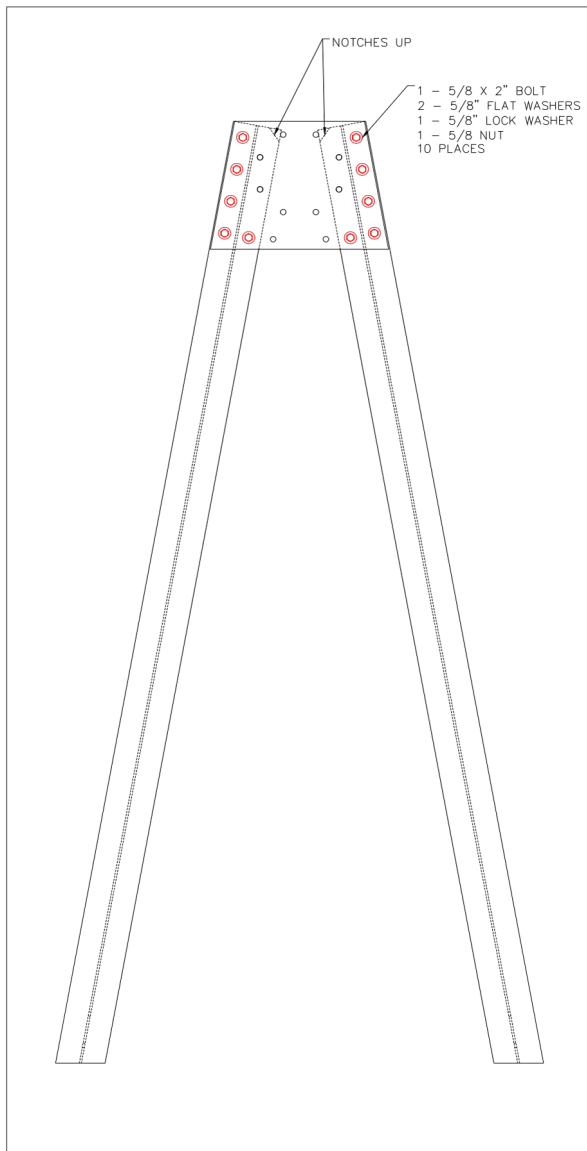

Figure 4-2 Assembly steps 1 and 2

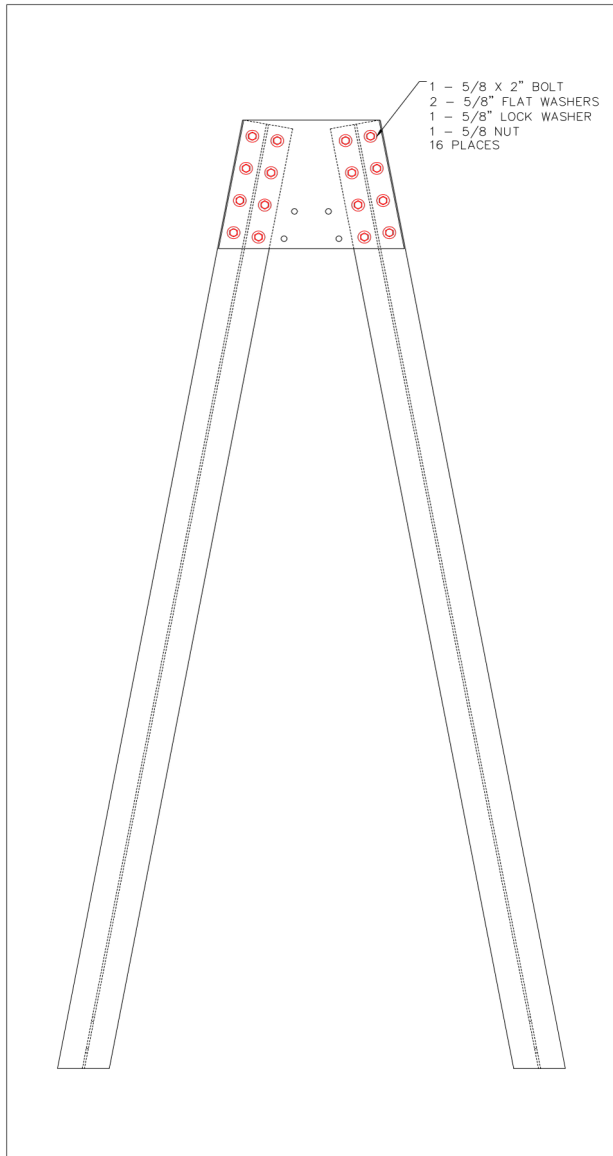

Figure 4-3 Assembly step 3

VBBA-NVIS Antenna System

- (4) Lay the left and right “joint side” legs (Items 4 and 5, Table 2-1) on the ground with the round notches facing upwards.
- (5) Place the front “joint side” plate (Item 13, Table 2-1) on top of the legs and loosely fasten the sixteen outside 5/8" bolts. Refer to Figure 4-4.
- (6) Flip the assy over and place the back “joint plate” (Item 12, Table 2-1) on the legs and loosely fasten all sixteen 5/8" x 2" bolts. Refer to Figure 4-5.

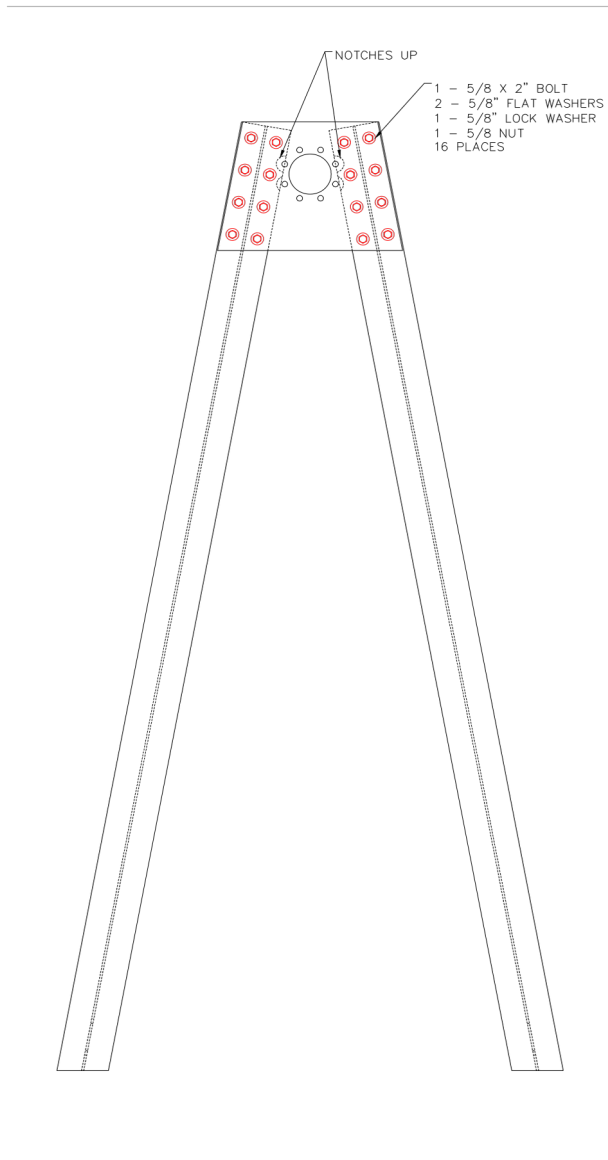

Figure 4-4 Assembly steps 4 and 5

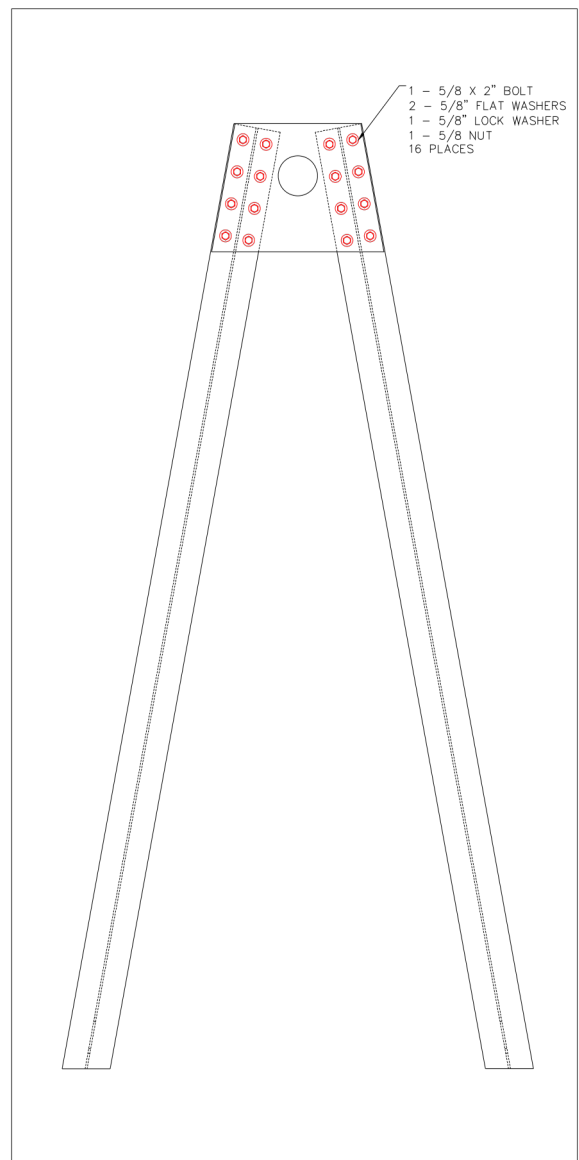

Figure 4-5 Assembly step 6

VBBA-NVIS Antenna System

- (7) Loosely fasten an inside clip (Item 14, Table 2-1) and an outside clip (Item 15, Table 2-1) on each of the main legs (four places) using four 1/2" x 2" bolts. Refer to Figure 4-6.

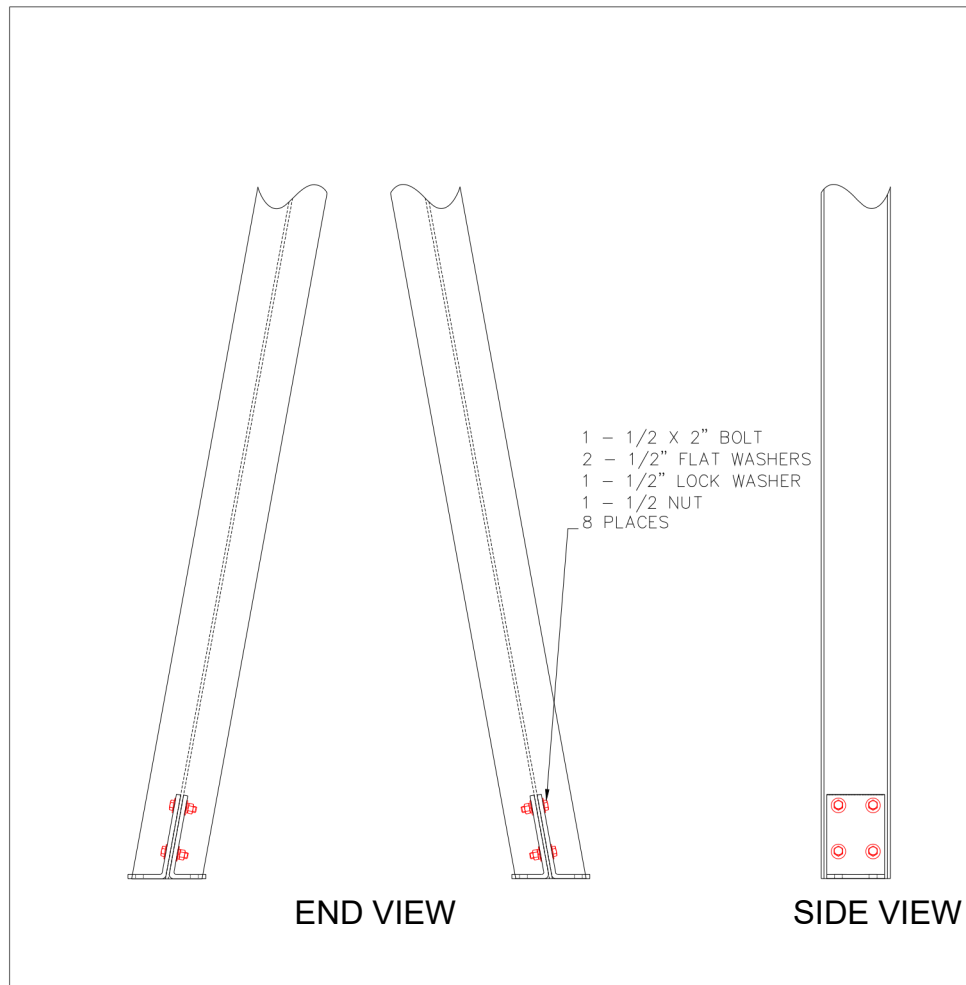

Figure 4-6 Assembly step 7

VBBA-NVIS Antenna System

- (8) Loosely fasten the left and right lower clips (Items 18 and 19, Table 2-1) to the bottom of the angle leg (Item 8, Table 2-1) using six 1/2" x 2" bolts. Refer to Figure 4-7.
- (9) Loosely fasten the left and right upper clips (Items 16 and 17, Table 2-1) to the top of the angle leg (Item 8, Table 2-1) using six 1/2" x 2" bolts. Refer to Figure 4-7.

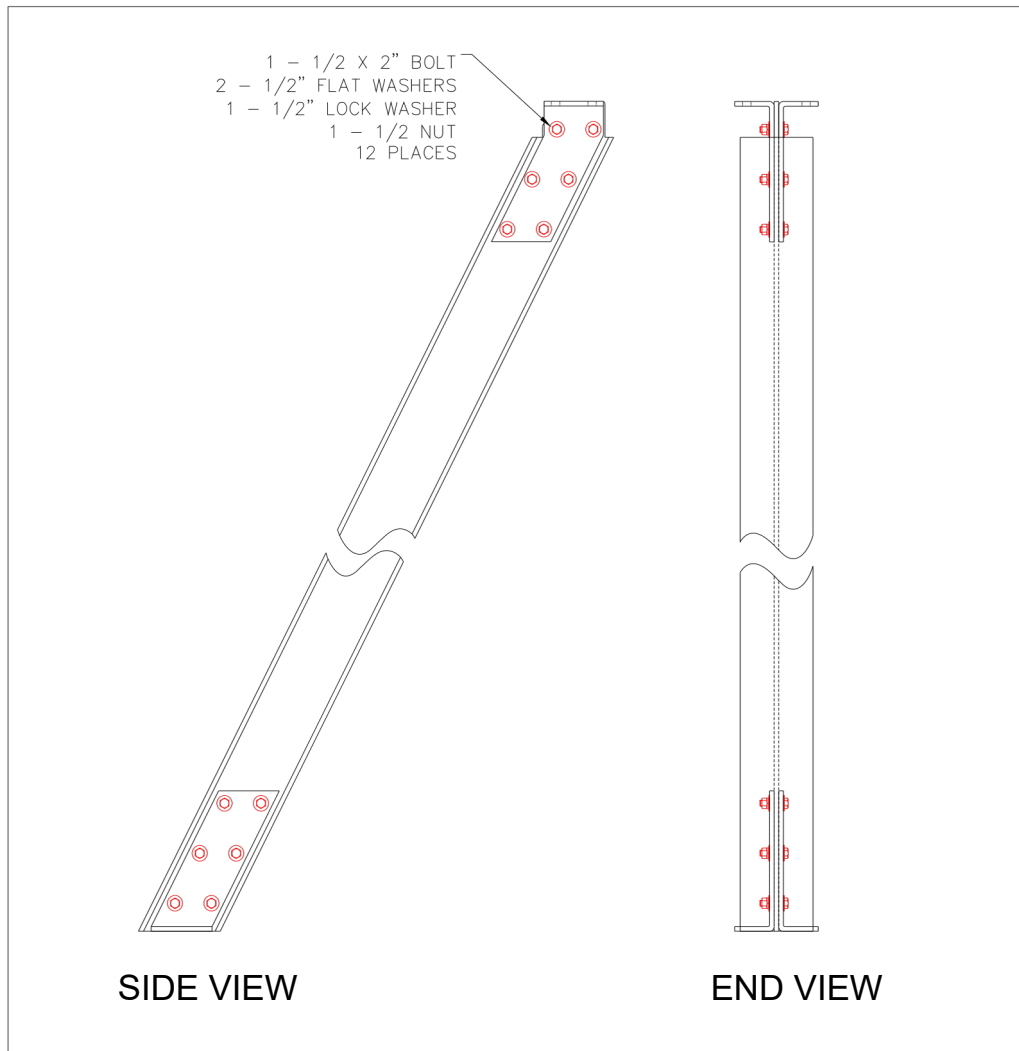

Figure 4-7 Assembly steps 8 and 9

VBBA-NVIS Antenna System

- (10) Securely fasten the Cross member (Item 9, Table 2-1) to the upper angle clips using the backing plate (Item 20, Table 2-1) and four 5/8" x 2-1/4" bolts. Apply a few drops of thread-locker (item 23, Table 2-1) to the threads before assembly. Refer to Figure 4-8.

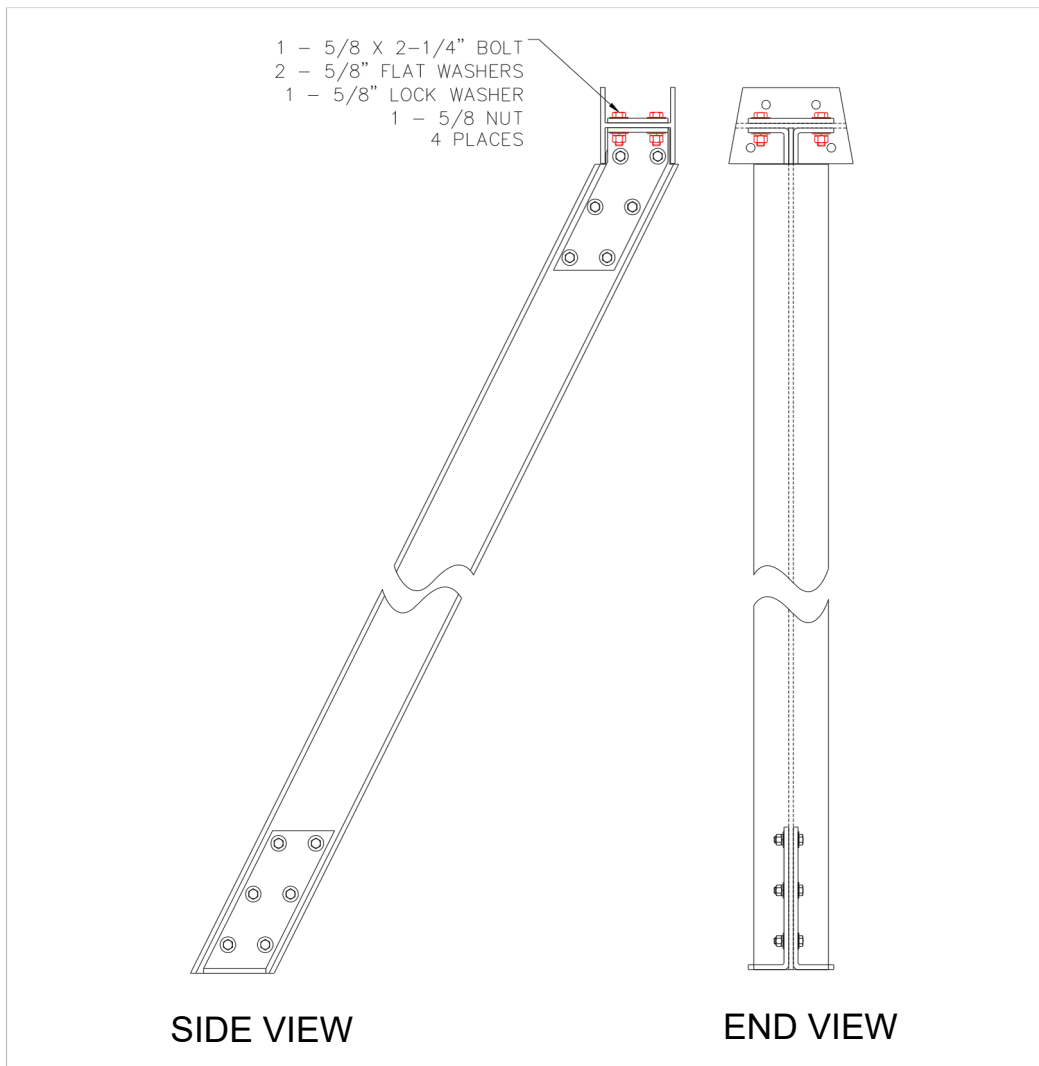

Figure 4-8 Assembly step 10

- (11) Insert the cross member of the angle leg assembly between the two "base side" plates, from the bottom and in between the two legs. Do so with the leg pointing out the same side as the "front" base plate. Loosely fasten with four 5/8" x 2" bolts on the back side and two 5/8" x 2" bolts on the front side (lower holes). Refer to Figure 4-9.

VBBA-NVIS Antenna System

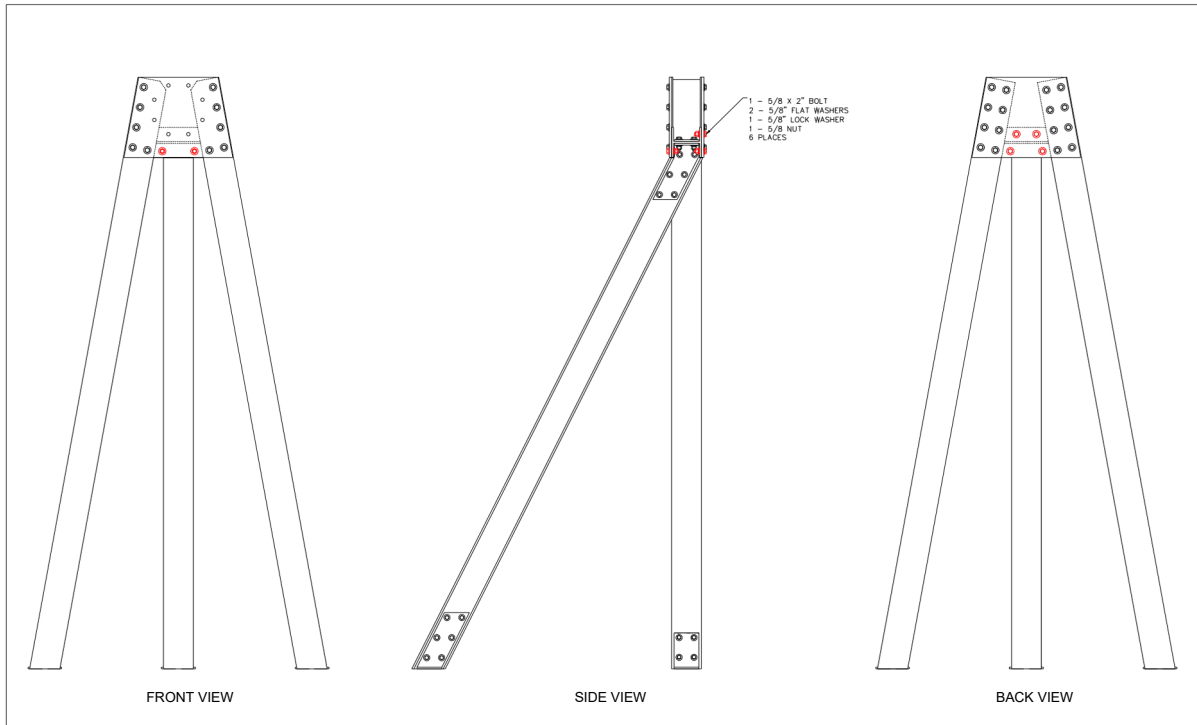

Figure 4-9 Assembly step 11

- (12) Install the antenna sleeve adapter (Item 2, Table 2-1) to the antenna base section (Item 1, Table 2-1) using eight of the 3/8" countersunk screws. Apply a film of anti-seize compound (Item 22, Table 2-1) to the mating surfaces of the antenna and adapter before assembly. A small amount of anti-seize on the screws can also be applied. Tighten the screws. Thread-locker is not necessary here. Ensure the feedpoint connector of the antenna is pointing downwards on the antenna as shown in Figure 4-10.

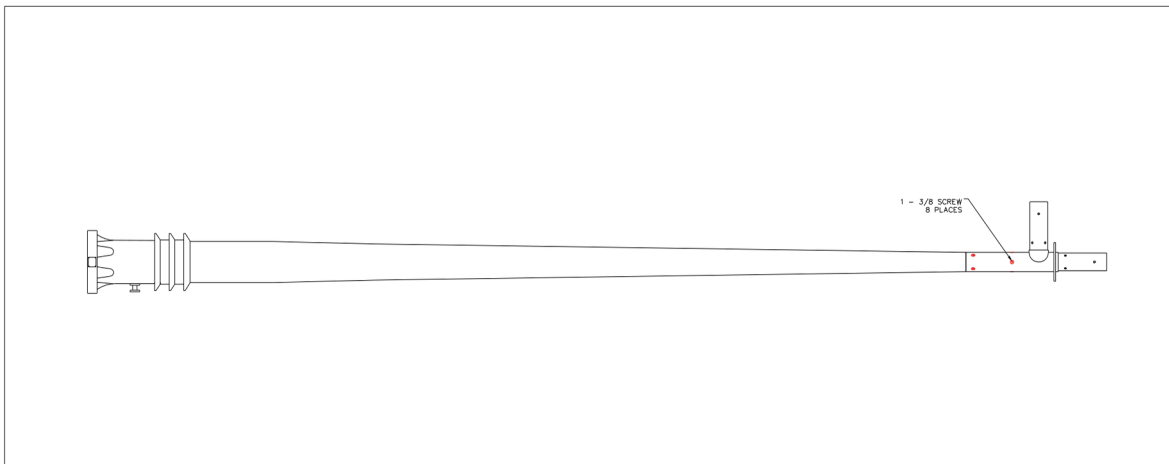

Figure 4-10 Assembly step 12

VBBA-NVIS Antenna System

- (13) Raise the three-legged assembly onto the foundation and loosely fasten the clips to the 5/8" anchor bolts in the concrete. Raise the two-legged assembly onto the foundation and loosely fasten the clips to the 5/8" anchor bolts in the concrete. Refer to Figure 4-11.

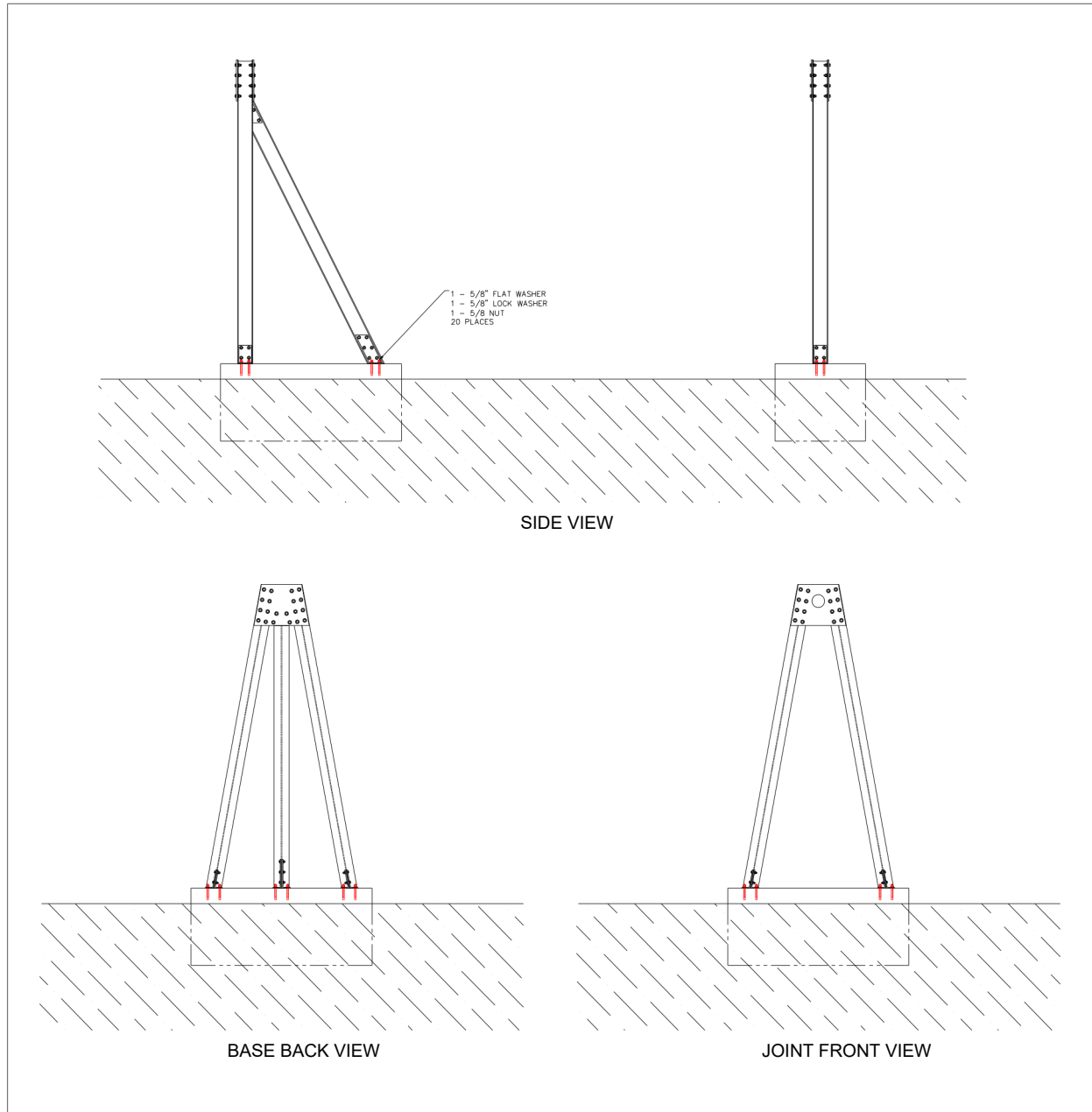

Figure 4-11 Assembly step 13

VBBA-NVIS Antenna System

- (14) Hoist the lower antenna section up horizontally, so that the adapter shaft fits into the holes of the two-legged assembly and then so that the base hole pattern lines up with the hole pattern in the front base side plate. The legs may need to be stretched out a bit to do this. Refer to Figure 4-12.

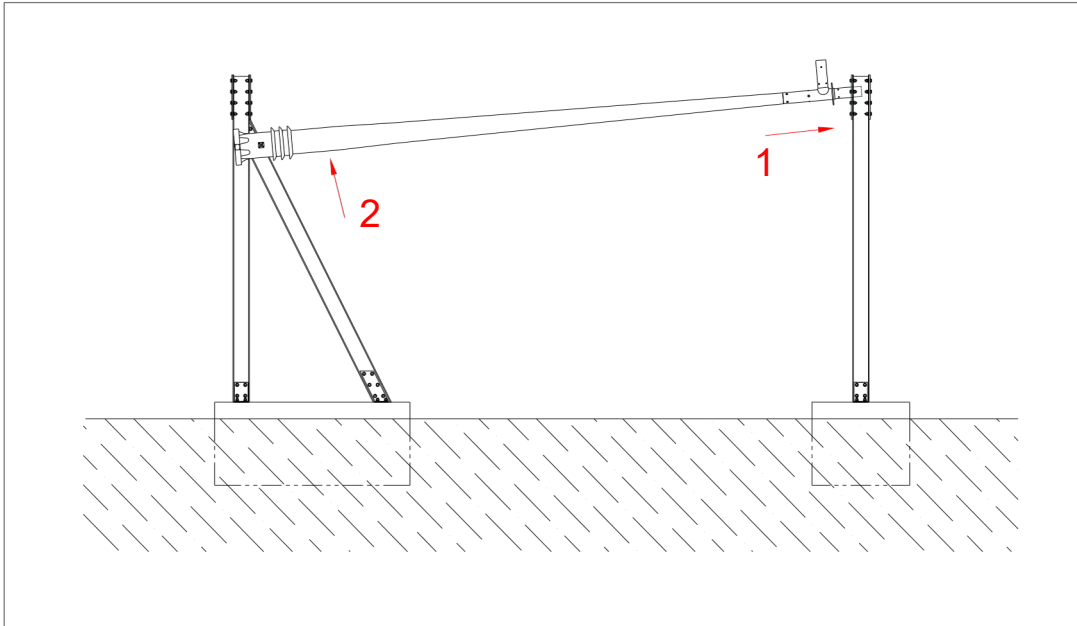

Figure 4-12 Assembly step 14

- (15) Securely fasten the base side of the antenna to the three-legged structure using eight 5/8" x 4" bolts. Apply a few drops of thread-locker (Item 23, Table 2-1) to the threads before assembly. Refer to Figure 4-13.
- (16) Securely fasten the joint side of the antenna to the two-legged structure using eight 5/8" x 2" bolts. Apply a few drops of thread-locker (Item 23, Table 2-1) to the threads before assembly. Refer to Figure 4-13.
- (17) Securely tighten all hardware previously only “loosely” installed. Apply a few drops of thread-locker (Item 23, Table 2-1) to the threads before assembly.

VBBA-NVIS Antenna System

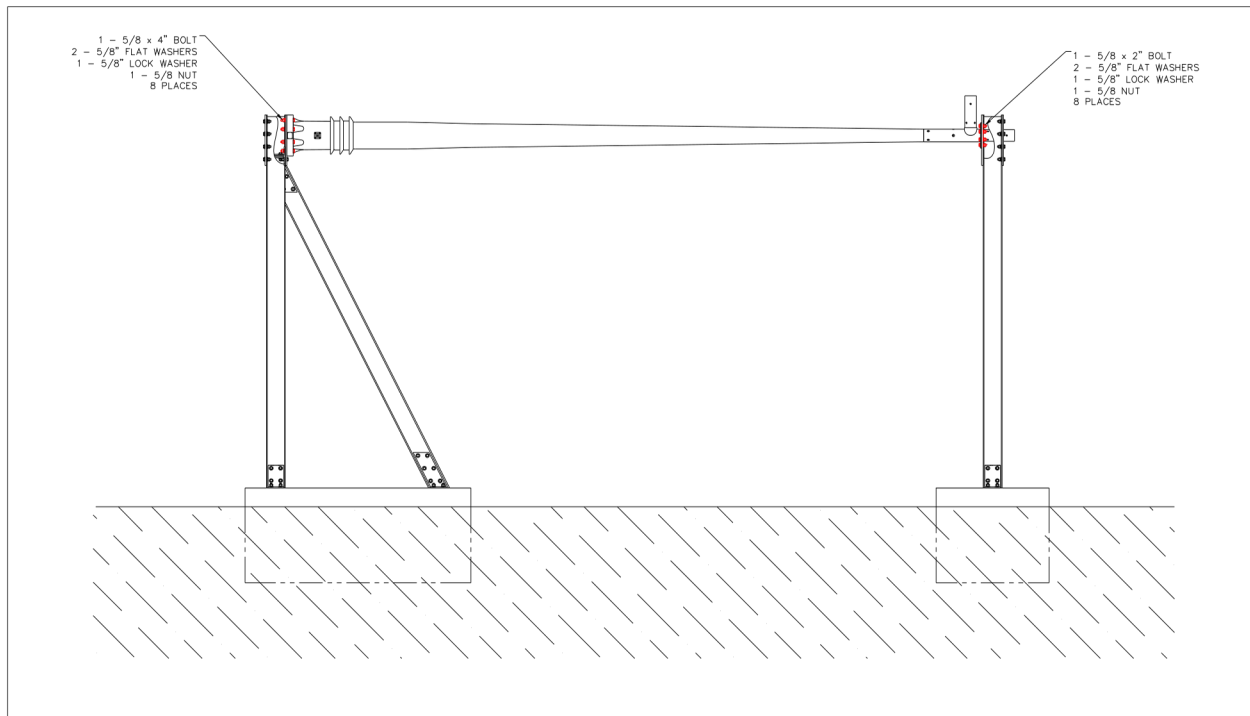

Figure 4-13 Assembly steps 15 and 16

- (18) Install one antenna whip section (Item 3, Table 2-1) to the horizontal sleeve of the sleeve adapter using eight of the 3/8" countersunk screws. Apply a film of anti-seize compound (Item 22, Table 2-1) to the mating surfaces of the antenna and adapter before assembly. A small amount of anti-seize on the screws can also be applied. Tighten the screws. Thread-locker is not necessary here. Refer to Figure 4-14
- (19) If provided, install the other antenna whip section (Item 3, Table 2-1) to the vertical sleeve of the sleeve adapter using eight of the 3/8" countersunk screws. Apply a film of anti-seize compound (Item 22, Table 2-1) to the mating surfaces of the antenna and adapter before assembly. A small amount of anti-seize on the screws can also be applied. Tighten the screws. Thread-locker is not necessary here. Refer to Figure 4-14.
- (20) Apply silicone sealant (Item 27, Table 2-1) over the heads of the counter-sunk screws

VBBA-NVIS Antenna System

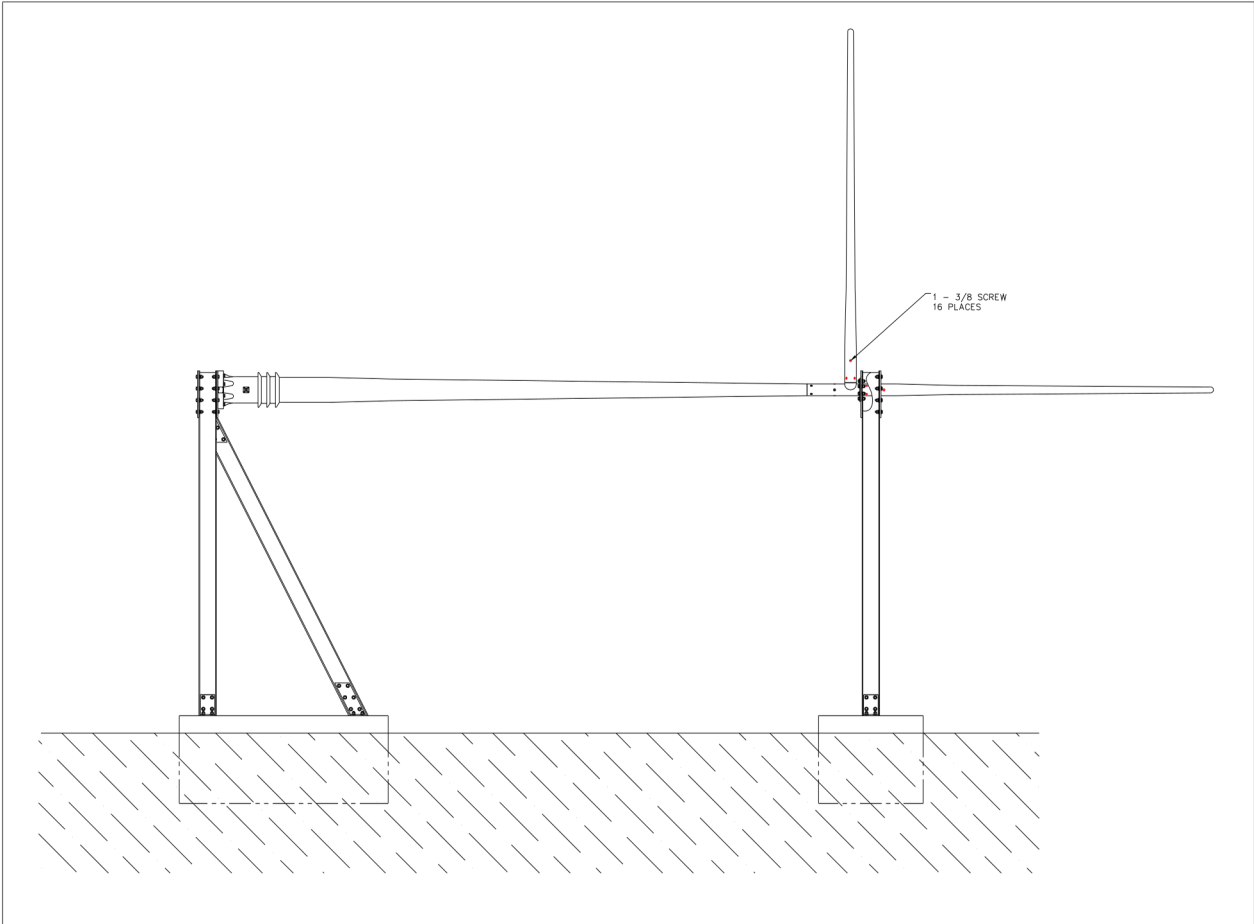

Figure 4-14 Assembly steps 18 and 19

VBBA-NVIS Antenna System

4.4 Ground Screen (Item 25, Table 2-1)

NOTE

Ground Screen is only required (and supplied) for land-based installations.

- (1) Lay the two radial assemblies on the ground between the two concrete pads to form an oval. Refer to the ground screen layout diagram in Section 8.0 of this manual.
- (2) Join the compression fittings on the two assemblies. Pigtail the two short wires together and braze the joint.
- (3) Install two ground rods inside the oval. Stretch out and connect the coiled wires to the ground rods with the clamps provided. Cut off excess wire and save. Braze the joint.
- (4) Unravel each radial outwards until all 18 radials have been spread out.
- (5) Install a ground rod into the ground at the end of each radial.
- (6) Fasten the radial to the ground rod with the clamps provided. Braze the joint.
- (7) Install the special ground rod between the oval and the 6ft x 6ft concrete pad. Use the excess wire from step 3 above and connect the two radials above and below the ground rod to the ground rod with the clamp provided. All joints should be brazed.
- (8) For safety and security reasons, it is recommended to bury all the components of the ground screen.

VBBA-NVIS Antenna System

5.0 SYSTEM TUNING AND CONNECTION

5.1 Tuning

No tuning is required for this system. The VBBA-NVIS has been designed to match to the 50 ohm feedline over the entire operating frequency band without the need of an external tuning device.

5.2 Electrical Connections

- (1) Connect the feedline cable (Item 24, Table 2-1) to the input connector of the antenna. Connect the other end of the cable to the connector found on the Special ground rod (Part of Item 25, Table 2-1) or a suitably grounded flange. Connect the feedline cable from the transmitter (not supplied) to the connector on the Special ground rod or suitable grounded flange.
- (2)

CAUTION

A new feedline will need to be made if using power levels beyond 1kW.
Use appropriate cable and connectors for the power rating.

No additional connections are necessary.

5.3 Testing

If desired, a Network analyzer can be used to verify the VSWR of the system. The response should look similar to the chart in Figure 5-1.

VBBA-NVIS Antenna System

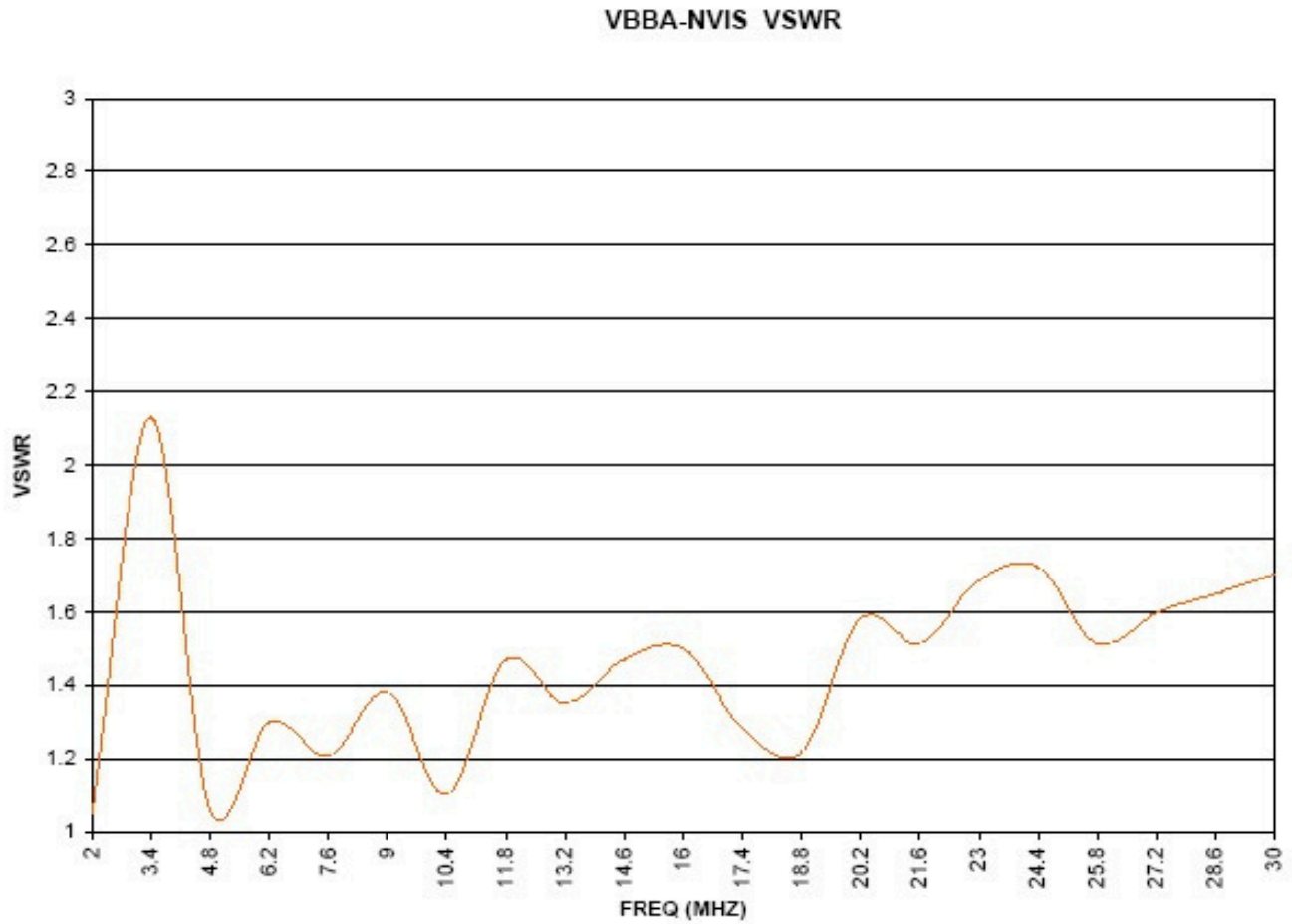

Figure 5-1 Typical VSWR response of the VBBA-NVIS Antenna System

VBBA-NVIS Antenna System

6.0 OPERATIONAL GUIDELINES

6.1 General

The VBBA-NVIS antenna system is designed for Near Vertical Incident Skywave (NVIS) HF (High Frequency) communications. It can also be used with the vertical whip option for local surface wave HF communications.

6.2 Local Surface Wave Comms

For operation using localized ground or surface wave communications, the optional vertical whip must be installed. This whip is supplied only if the antenna was ordered with it. To operate the antenna system for localized ground wave communications, no settings or adjustments need to be made. Simply choose a frequency and transmit.

6.3 NVIS Comms

For operation using NVIS methods, the installation of the optional vertical whip does not matter. In other words, it can be installed or not installed. Therefore, nothing additional needs to be set or adjusted with the antenna system for NVIS operation. In choosing NVIS operation, a number of factors need to be considered. These include, frequency, time of day and antenna gain. Theoretical antenna gain plots are included in Section 8.0 of this manual.

VBBA-NVIS Antenna System

7.0 MAINTENANCE

7.1 Scheduled Maintenance

The antenna is virtually maintenance free. The external finish is a very durable silicone alkyd paint. The minimum finish life before showing signs of deterioration should be at least six years under normal climate conditions.

Every six months or when deemed necessary:

- S Inspect the antenna input connector for signs of excessive corrosion or debris.
- S Inspect all hardware and ensure nothing has come loose or broken.
- S Inspect the ground system and ensure it is still in decent condition. Note, if the VSWR spike at 3.4 MHZ ever disappears to below about a 1.2:1 match, there is possibly a problem with the ground screen.
Wash the antenna base with fresh water to remove any build-up of dried salt residue.

- S

7.2 Corrective Maintenance

Generally, for the antenna, no corrective maintenance is possible or required. If one component is severely damaged, it must be replaced. Contact Valcom for replacement instructions or advice on performing possible repairs.

WARNING

DO NOT USE LEAD BASE PAINT TO TOUCH-UP OR REPAINT
ANY COMPONENT OF THE SYSTEM.
EPOXY-BASED PAINT IS RECOMMENDED.

VBBA-NVIS Antenna System

8.0 ADDITIONAL REFERENCE DATA

8.1 Contact Information

Valcom can be contacted by any of the following means:

Postal address:	Shipping address:
Valcom Manufacturing Group, Inc P.O. Box 603 Guelph, Ontario Canada N1H 6L3	Valcom Manufacturing Group, Inc 175 Southgate Drive Hanlon Industrial Park Guelph, Ontario Canada N1G 3M5
Or directly at:	
Phone : (519)824 - 3220 Fax : (519) 824 - 3411 e-mail : sales@valcomguelph.com Internet : www.valcommfg.ca	

8.2 Associated Components

Additional reference engineering data for use during planning and installation activities for the VBBA-NVIS Antenna System is presented on the following page(s).

- * Recommended Foundation Details
- * Ground Screen Layout Details

VBBA-NVIS Antenna System

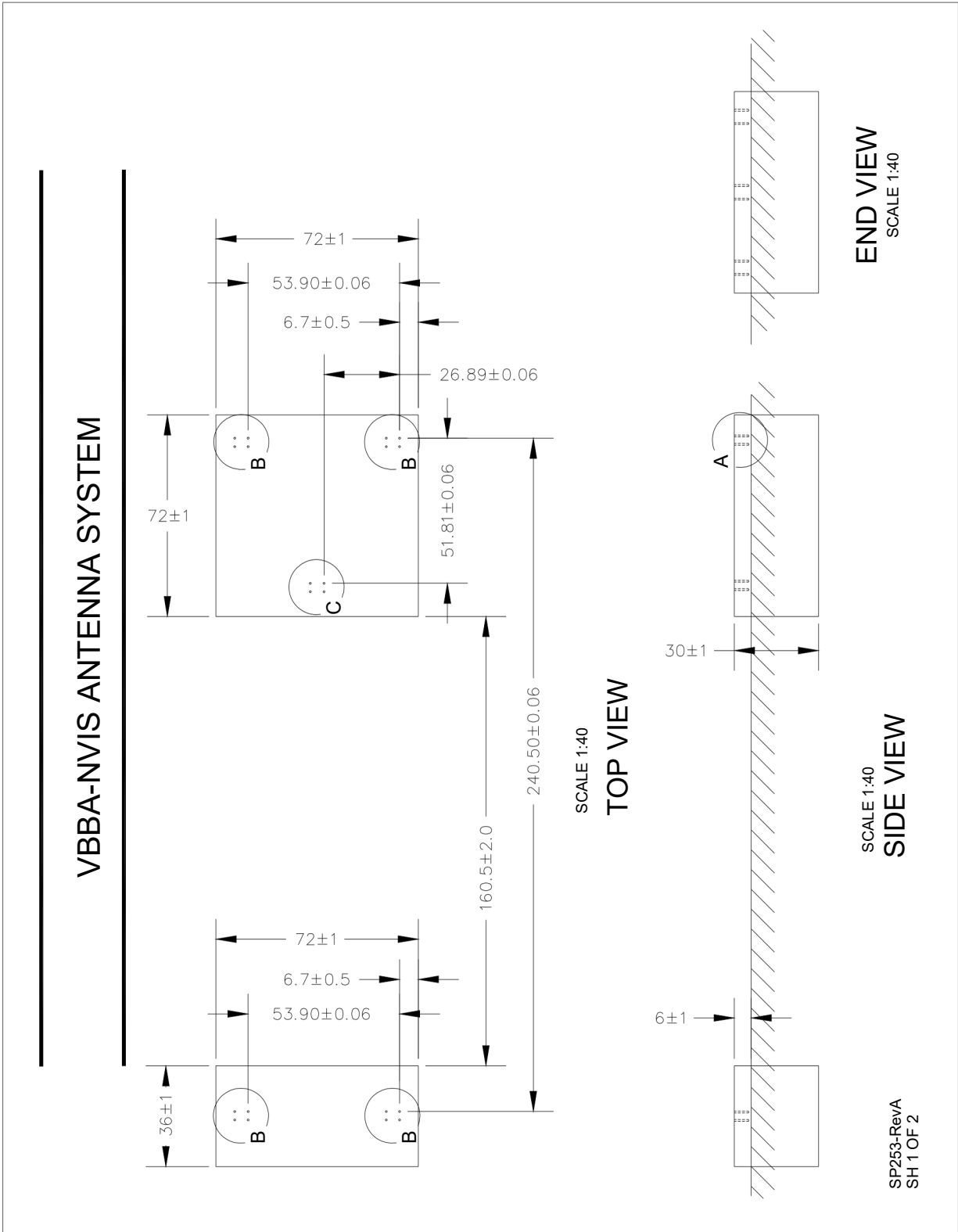

FOUNDATION DETAILS FOR VBBA-NVIS ANTENNA SYSTEM

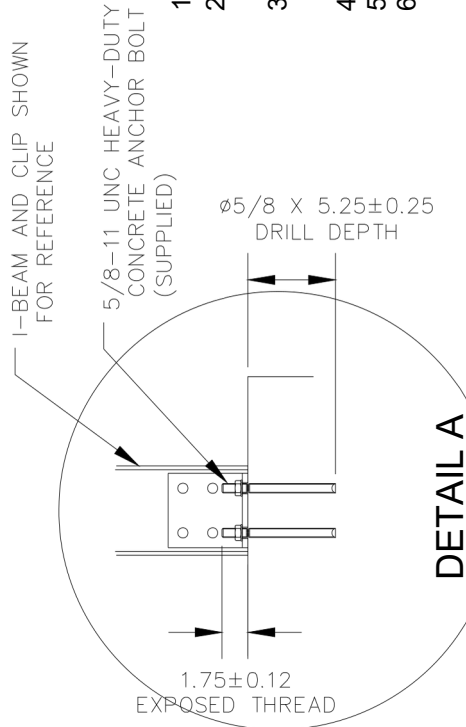

DETAIL A

SCALE 1:10

Notes:

- 1.Foundation base to be on undisturbed soil.
- 2.Foundation excavation must be free of water before placement of concrete.
- 3.During placement of concrete, maximum free fall distance shall not exceed four feet (120cm).
- 4.Minimum 28-day compressive strength-4000 PSI.
- 5.Air entrained concrete 6% ±1%.
6. Design based on frost-free location. If frost will penetrate more than depth of footing, increase depth of footing to maximum frost depth plus 6 inches (15cm).
7. Maximum tightening torque on anchor bolts is 75 ft-lbs.

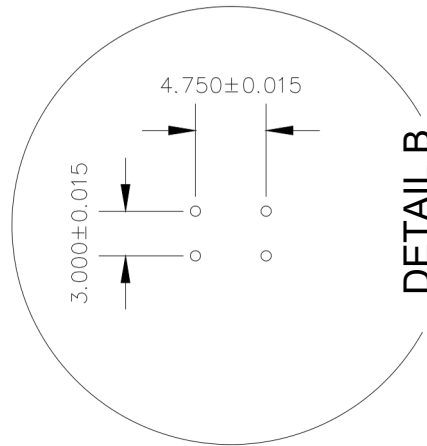

DETAIL B

SCALE 1:10

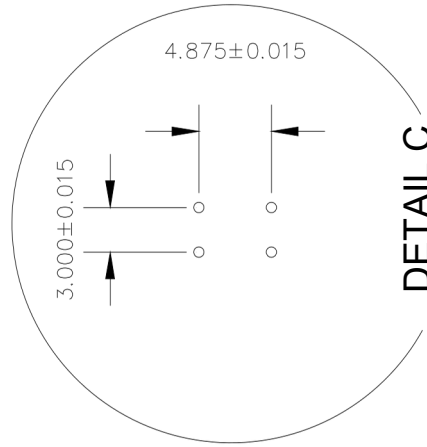

DETAIL C

SCALE 1:10

SP253
SH 2 OF 2

VBBA-NVIS Antenna System

**GROUND SCREEN LAYOUT DETAILS FOR
VBBA-NVIS ANTENNA SYSTEM**

